

# MODEL 1200



004.12.00001

# MODEL 1200

DESCRIPTION : STEEL STRUCTURE AND COVERS

ITEM CODE : -

| PART ID      | DESCRIPTION                                  | QTY |
|--------------|--|-----|
| 001.12.00021 | COVER - TOP                                  | 1   |
| 001.00.00097 | INOX TAPED SCREW M5X25                       | 2   |
| 003.12.00004 | CONTROL PANEL - COMPLETE                     | 1   |
| 003.00.00242 | HEX INOX SCREW M6x12 (TOP COVER SUPPORT)     | 2   |
| 003.12.00004 | DISPLAY PANEL COMPLETE MOD1200               | 1   |
| 001.12.00019 | DOOR COMPLETE MOD1200                        | 1   |
| 001.12.00020 | COVER - FRONT                                | 1   |
| 001.12.00022 | COVER - SIDES DX AND SX                      | 2   |
| 003.00.00042 | HEX BOLT (TOP-SIDE COVERS SUPPORT)           | 6   |
| 001.00.00204 | LOCK WASHER (TOP-SIDE COVERS SUPPORT)        | 6   |
| 003.00.00516 | WASHER (TOP-SIDE COVERS SUPPORT)             | 6   |
| 001.00.00262 | INOX TAPED SCREW M5x16 (SIDE COVERS SUPPORT) | 4   |

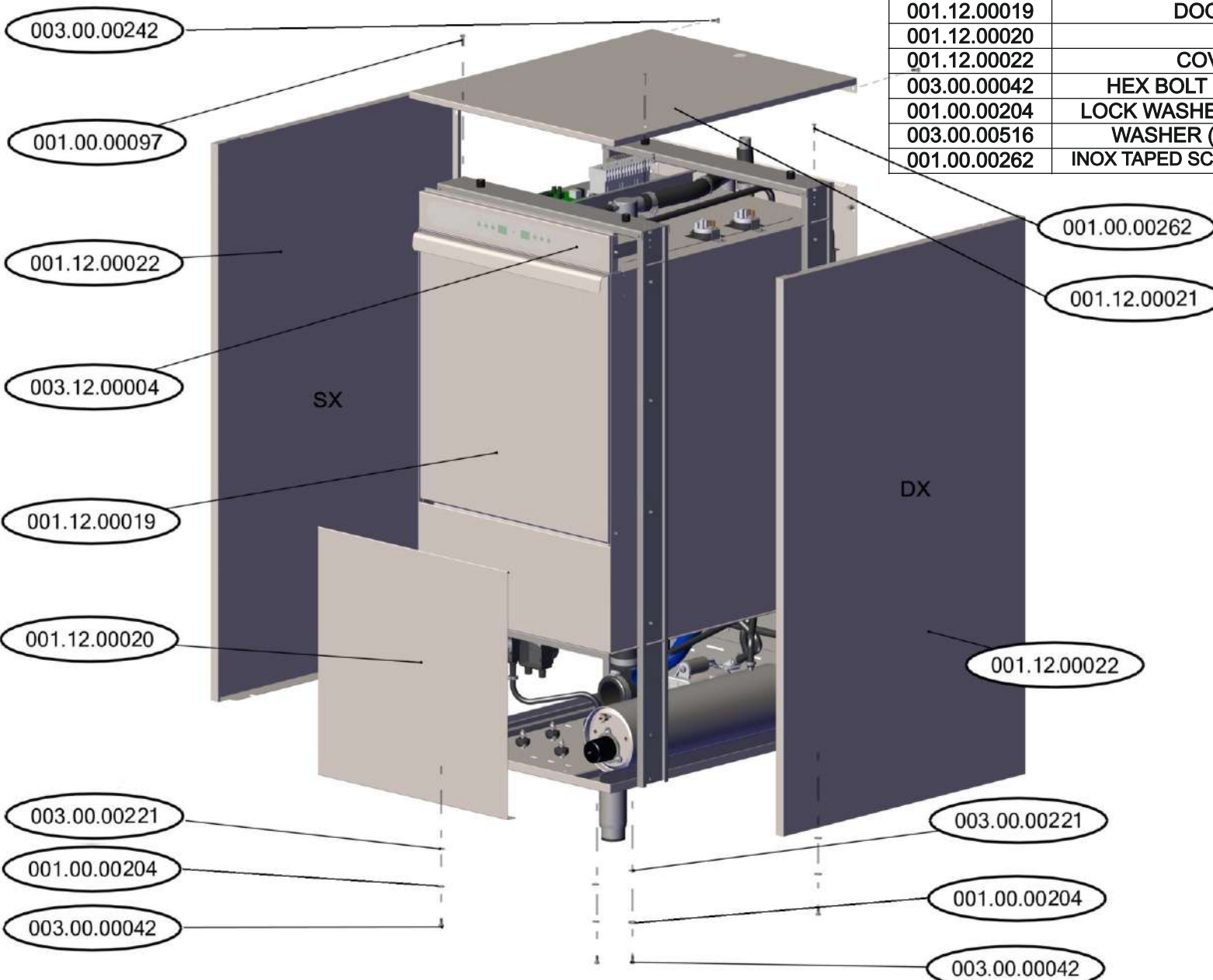

### MODEL 1200

DESCRIPTION : STEEL STRUCTURE AND COVERS

ITEM CODE : -

| PART ID      | DESCRIPTION                           | QTY |
|--------------|---------------------------------------|-----|
| 001.12.00023 | COVER - BACK - TOP                    | 1   |
| 003.00.00242 | HEX INOX SCREW M6x12 (BACK-TOP COVER) | 6   |
| 001.12.00029 | COVER - BACK - BOTTOM                 | 1   |
| 001.00.00280 | WASHER INOX D4x10                     | 4   |
| 003.00.00278 | HEX BOLT M4x10                        | 4   |

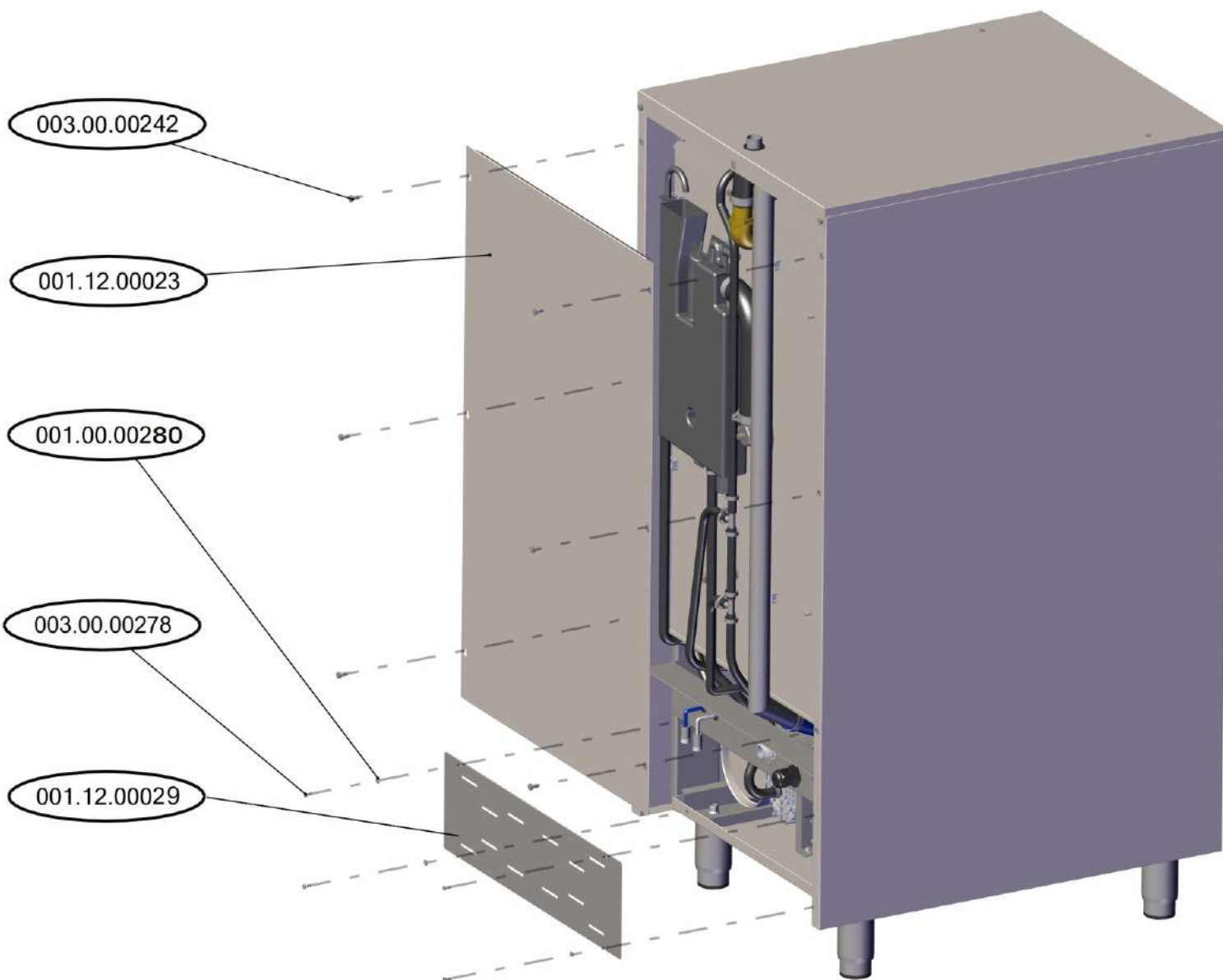

# MODEL 1200

DESCRIPTION : DOOR SUPPORT - DOOR ASSEMBLY

ITEM CODE : -

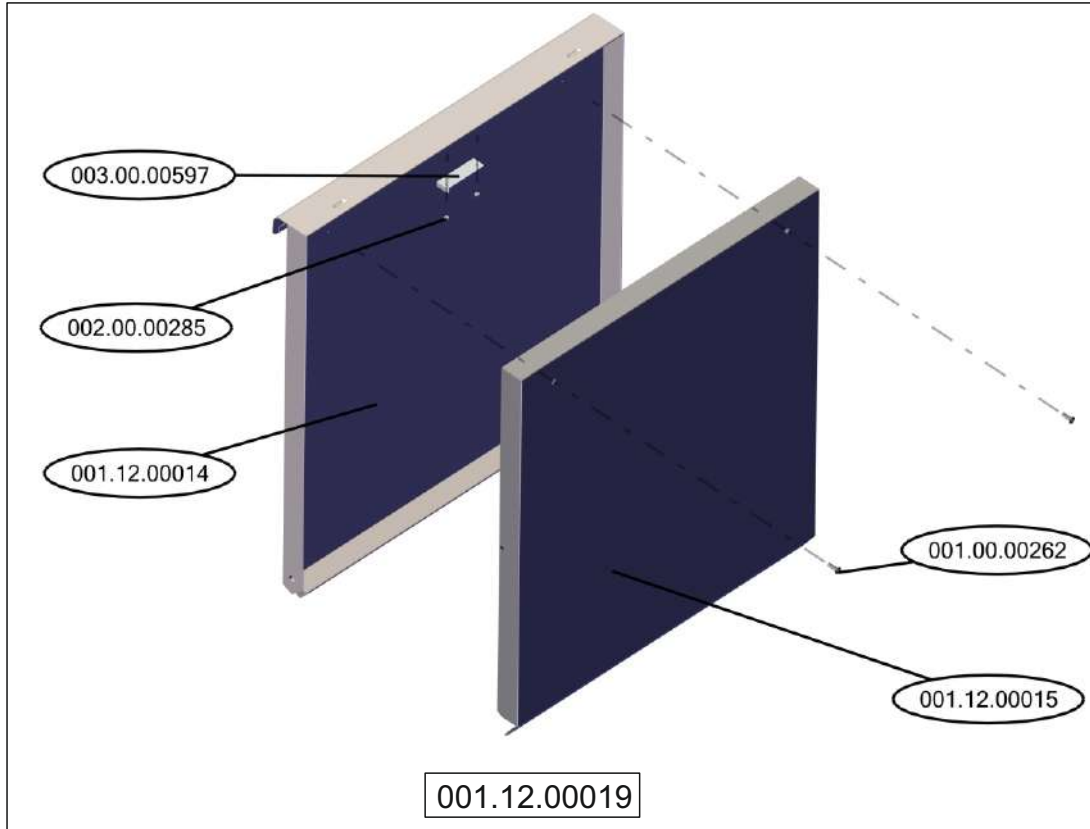

| PART ID      | DESCRIPTION                    | QTY |
|--------------|--------------------------------|-----|
| 001.12.00014 | DOOR - EXTERNAL PART           | 1   |
| 001.12.00015 | DOOR - INTERNAL PART           | 1   |
| 001.00.00262 | INOX TAPPERD SCREW M5X16       | 2   |
| 002.00.00285 | INOX NUT M3                    | 2   |
| 003.00.00597 | MAGNETIC UNIT                  | 1   |
| 001.00.00110 | DOMED CAP NUT M6               | 2   |
| 001.00.00192 | DOOR SUPPORT AXLE M6X420 Dx-Sx | 1+1 |
| 001.00.00073 | INOX SCREW 2.9x10              | 2   |
| 001.00.00221 | PLASTIC GUIDE FOR DOOR AXLE    | 2   |
| 001.60.00035 | DOOR SUPPORT $\Phi$ 9-M6 E600  | 2   |
| 003.00.00642 | INOX TAPPERD SCREW M6X10       | 2   |

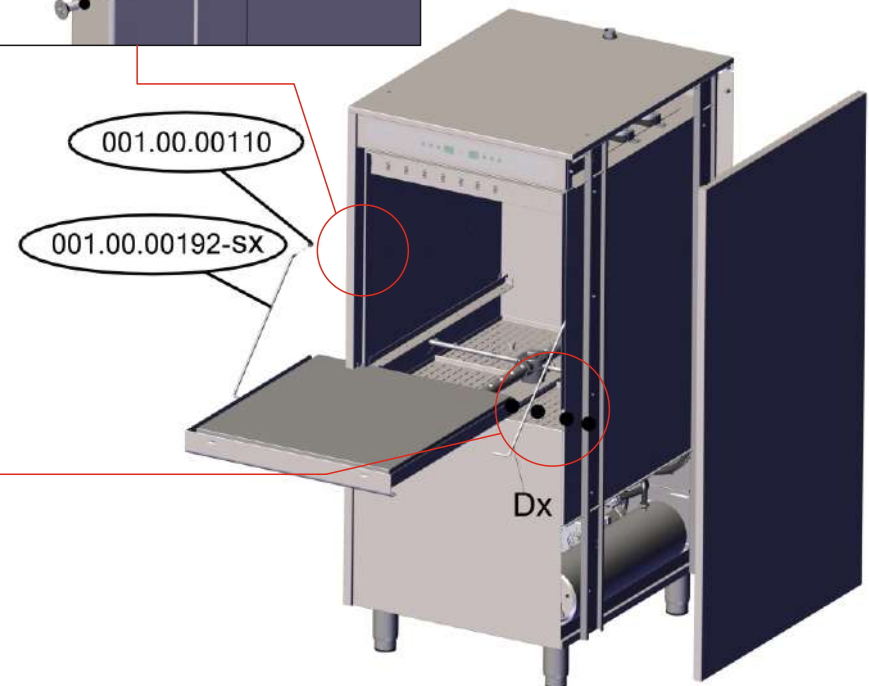
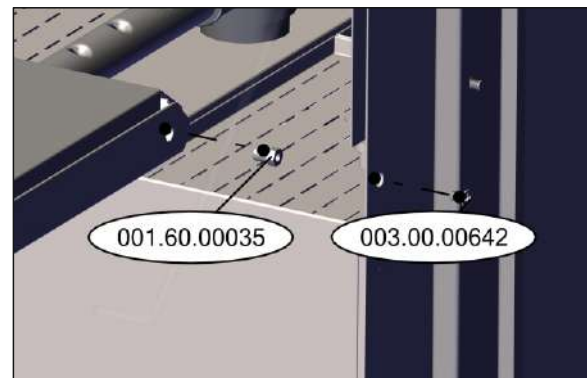
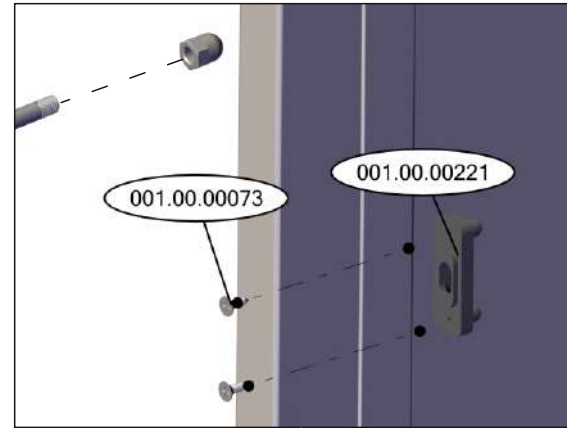

### MODEL 1200

DESCRIPTION : ELECTROMECHANICAL EQUIPMENT -TOP

ITEM CODE : -

| PART ID             | DESCRIPTION                                      | QTY |
|---------------------|--|-----|
| 003.12.00004        | CONTROL PANEL - COMPLETE                         | 1   |
| 003.00.00580        | MACHINE SCREW M4x10 mm (CONTROL PANEL SUPPORT)   | 2   |
| 003.00.00041        | NUT M6 (CONTROL PANEL SUPPORT)                   | 2   |
| 006.12.00000        | ELECTRICAL BOX MODEL 1200                        | 1   |
| 001.00.00045        | TEFLON WASHER $\Phi$ 12,5 X 8 X 2,5              | 4   |
| 003.00.00041        | NUT M6 (ELECTRICAL BOX SUPPORT)                  | 4   |
| 003.12.00002        | TOP COVER SPACER                                 | 4   |
| 001.00.00097        | INOX TAPPERD SCREW M5X25                         | 4   |
| 001.12.00048        | INOX PIPE D34x50 (STEAM RELEASE)                 | 1   |
| 002.00.00314        | PRESSURE PIPE 35-45 MODEL 1200                   | 1   |
| 002.00.00048        | CLAMP 35-50                                      | 2   |
| 002.00.00123        | RUBBER SHEET - 1200                              | 2   |
| 003.00.00033        | PRESSOSTAT SWITCH                                | 2   |
| 001.35.00028        | PRESSOSTAT SUPPORT                               | 2   |
| 003.00.00200        | TAPPING SCREW 3,5x9,5 GALV                       | 2   |
| 003.00.00046        | NUT M4 GALV                                      | 2   |
| 002.00.00119-1200-1 | WASHING MACHINE HOSE BLACK 10X16,5<br>L : 1150mm | 1   |
| 002.00.00047        | CLAMP 12-22                                      | 2   |

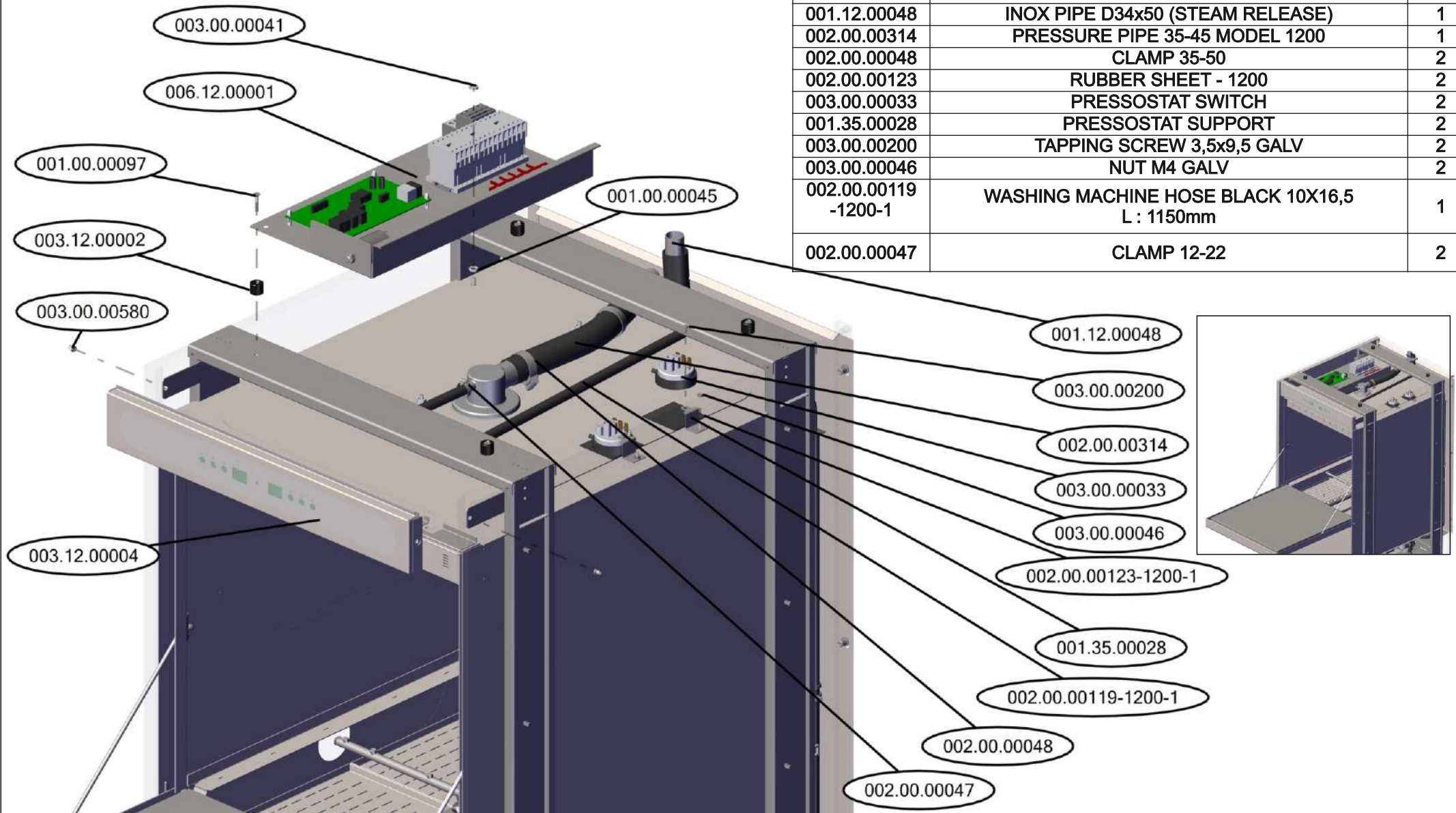

**MODEL 1200**

DESCRIPTION : ELECTRICAL BOX

ITEM CODE : 006.12.00001

| PART ID      | DESCRIPTION                                   | QTY |
|--------------|---|-----|
| 001.12.00031 | INOX BASE FOR ELECTRICAL BOX                  | 1   |
| 003.12.00005 | ELECTRICAL BOX COVER MODEL1200                | 1   |
| 003.00.00030 | POWER SUPPLY BOARD 6con.                      | 1   |
| 002.00.00046 | NUT M6 GALVANISED                             | 3   |
| 003.00.00607 | ATLAS MAIN BOARD VERSION                      | 1   |
| 003.00.00630 | SPACER PLASTIC PCB RC-14                      | 4   |
| 003.00.00625 | ELECTROMAGNETIC FILTER 250V 50/60Hz           | 1   |
| 003.00.00301 | NUT M8 GALV                                   | 1   |
| 003.00.00056 | MAGNETIC CONTACTOR MINI (1NO)                 | 3   |
| 003.00.00193 | THERMAL OVERLOAD RELAY 4,0-6,0                | 1   |
| 003.12.00003 | MAIN WIRING SET A1200 NED<br>(NOT VISIBLE)    | 1   |
| 003.00.00587 | THERMOCOUPLE SENSOR NTC 1.5M<br>(NOT VISIBLE) | 2   |

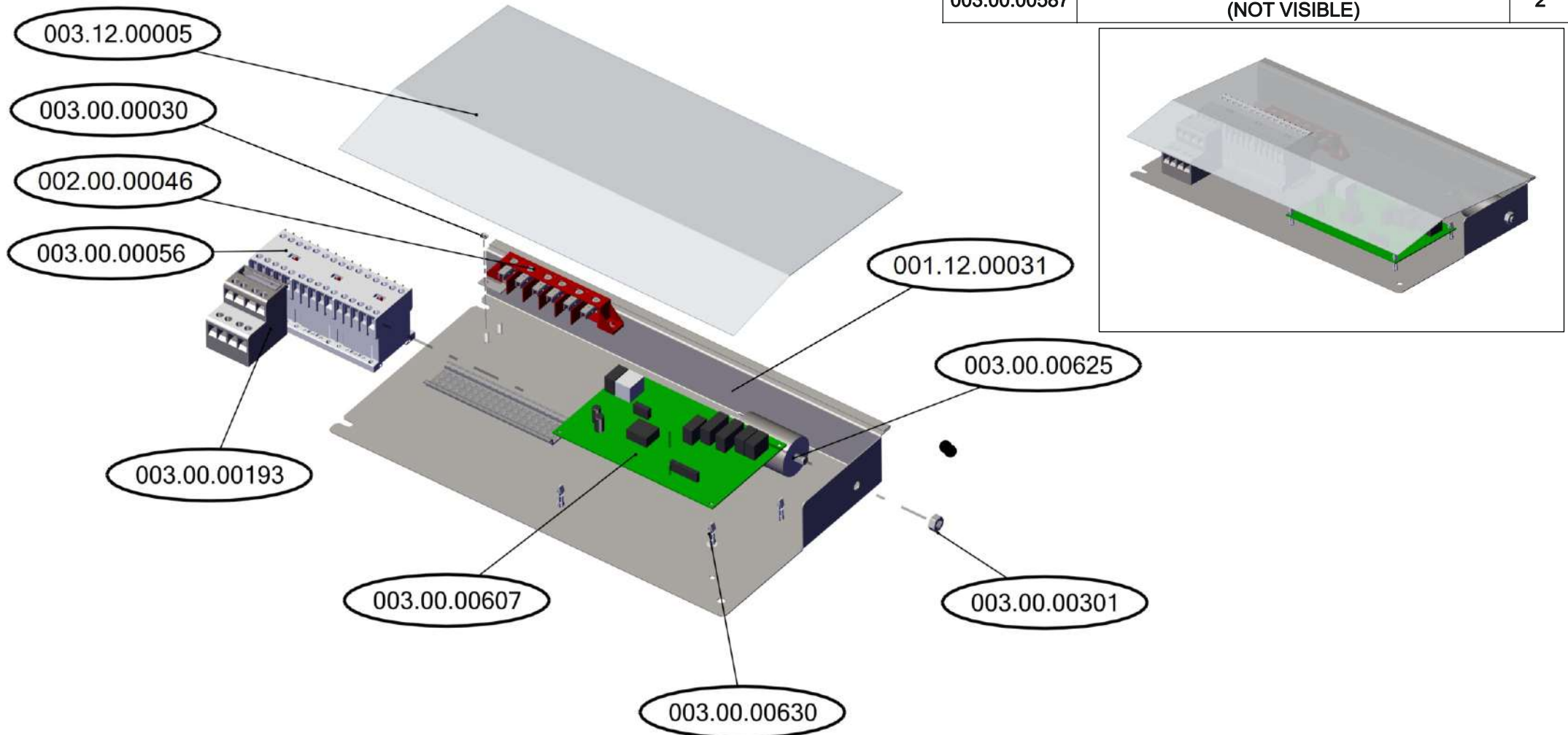

**MODEL 1200**

DESCRIPTION : CONTROL PANEL MODEL 1200

ITEM CODE : 003.12.00004

| PART ID      | DESCRIPTION                            | QTY |
|--------------|--|-----|
| 001.12.00027 | CONTROL PANEL - STEEL BASE             | 1   |
| 003.12.00000 | FILM FOR A1200 (LCD)                   | 1   |
| 003.00.00609 | USER INTERFACE 7 SEGM. DISPLAY VERSION | 1   |
| 003.00.00659 | PCU SPACER 3.4x6x5                     | 4   |
| 003.00.00598 | MAGNETIC SENSOR                        | 1   |
| 002.00.00090 | NUT M3 GALV                            | 6   |

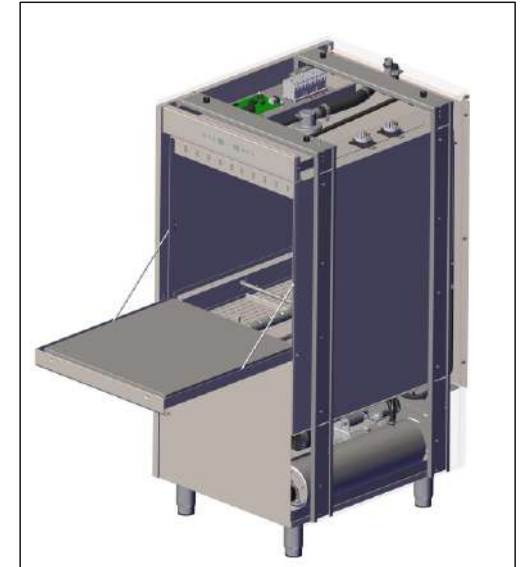
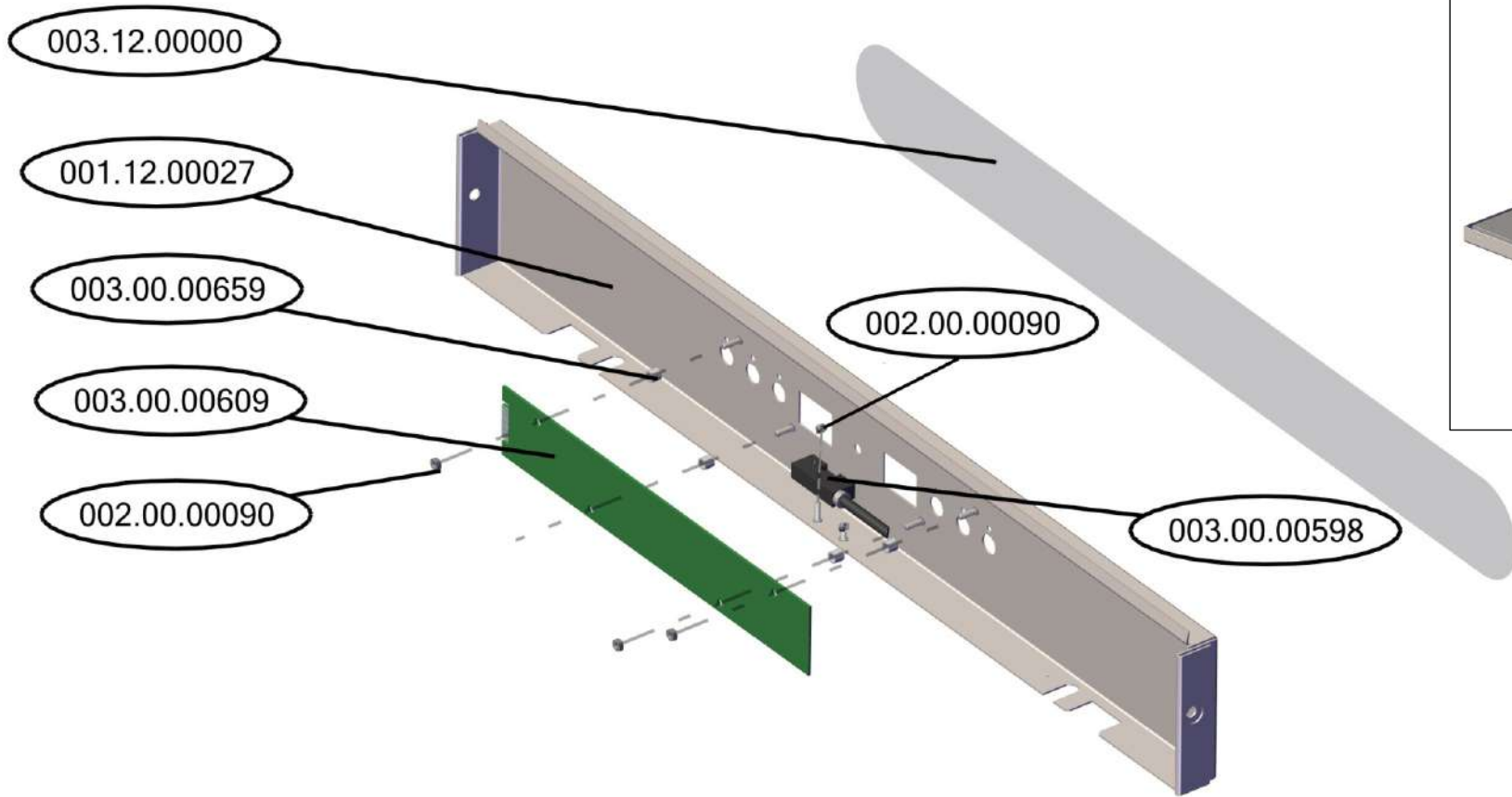

**MODEL 1200**

DESCRIPTION : ELECTROMECHANICAL EQUIPMENT - BACK

ITEM CODE : -

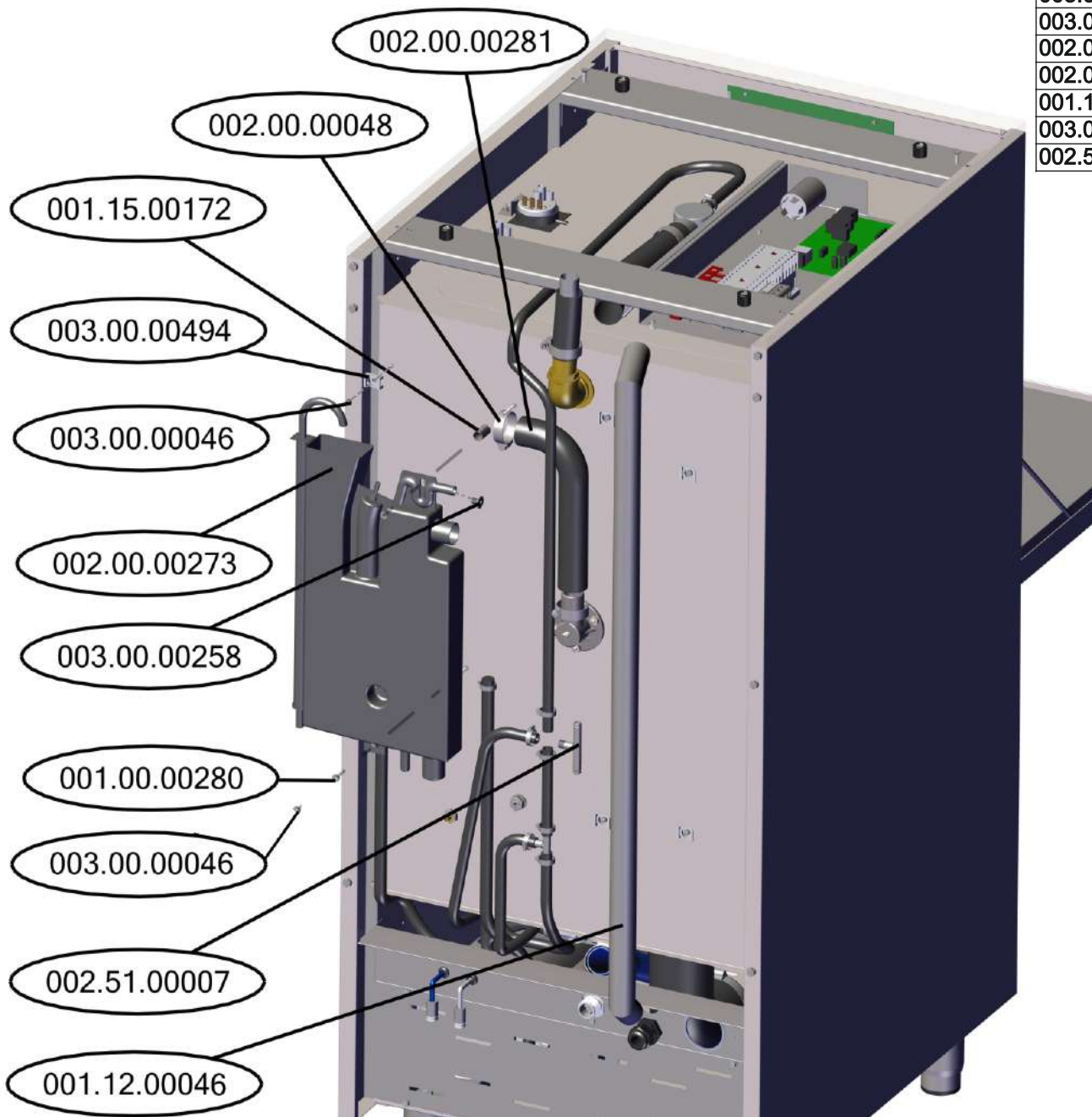

| PART ID      | DESCRIPTION                     | QTY |
|--------------|---------------------------------|-----|
| 002.00.00273 | BREAK TANK ASSEMBLY 2,4Lt       | 1   |
| 001.15.00172 | INOX HOOD SPACER 1500 Φ12/10X23 | 2   |
| 001.00.00280 | WASHER INOX Φ4X10               | 2   |
| 003.00.00046 | NUT M4 GALV                     | 8   |
| 003.00.00258 | INOX SCREW M8x12 ALLEN          | 1   |
| 002.00.00281 | ELBOW HOSE Φ38-Φ30 210X130      | 1   |
| 002.00.00048 | CLAMP 25-40                     | 2   |
| 001.12.00046 | WASH SUPPLY INOX MODEL1200      | 1   |
| 003.00.00494 | CABLE PLASTIC CLAMP             | 6   |
| 002.51.00007 | T-CONNECTION                    | 2   |

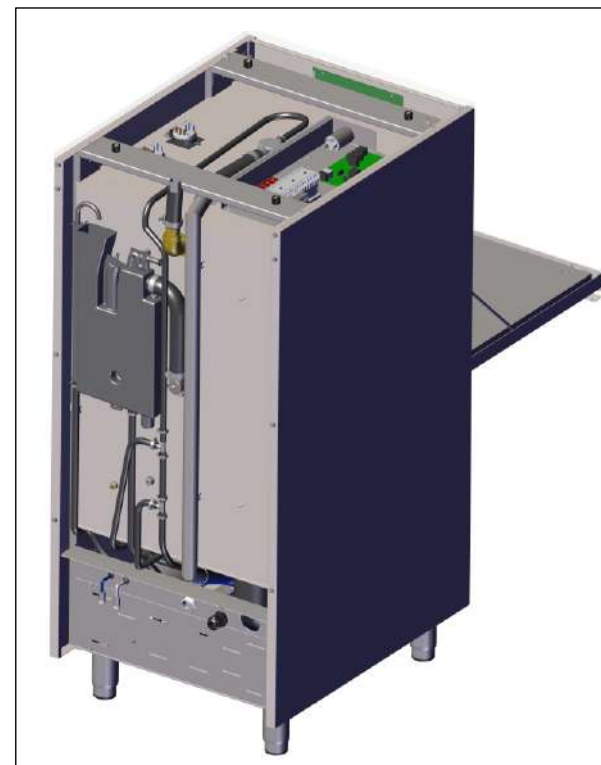



**MODEL 1200**

DESCRIPTION : ELECTROMECHANICAL EQUIPMENT - TOP - BACK

ITEM CODE : -

| PART ID      | DESCRIPTION                     | QTY |
|--------------|---------------------------------|-----|
| 002.12.00001 | UPPER WASH BASE 1200            | 1   |
| 002.12.00003 | O-RING 6225 OR 160 NBR          | 1   |
| 002.12.00002 | PLASTIC NUT FOR UPPER BASE 1200 | 1   |
| 002.12.00004 | INOX AXLE FOR UPPER BASE 1200   | 1   |
| 002.12.00015 | WASH&RINSE CROSS A1200 COMPLETE | 1   |
| 001.00.00051 | DOOR SNAP SET                   | 2   |
| 002.12.00014 | NUT 1"                          | 1   |
| 002.12.00013 | WASHER D55x35                   | 1   |
| 002.12.00012 | GASKET 1"                       | 1   |
| 002.12.00011 | THREAD NIPPLE 1" L40            | 1   |
| 002.12.00010 | HOSE NIPPLE 1" D35              | 1   |
| 002.12.00009 | ANGLE F/F 1" D35                | 1   |
| 002.00.00159 | O RING10X1,5                    | 2   |

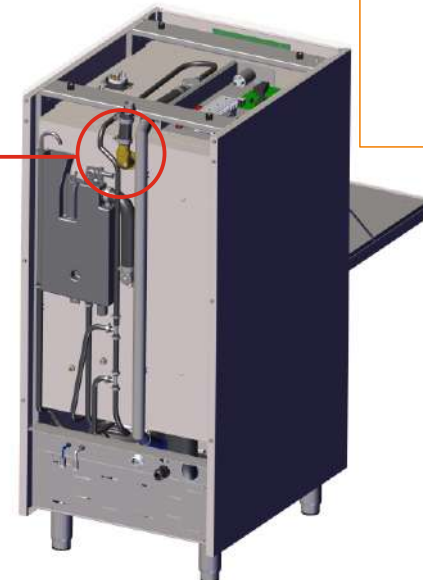
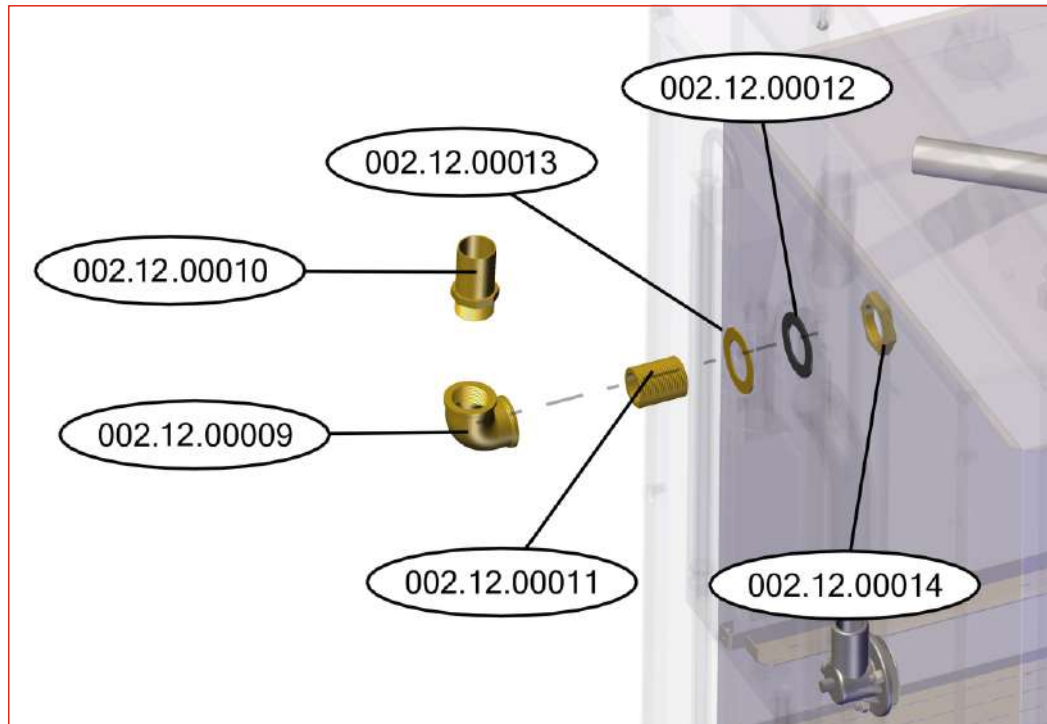
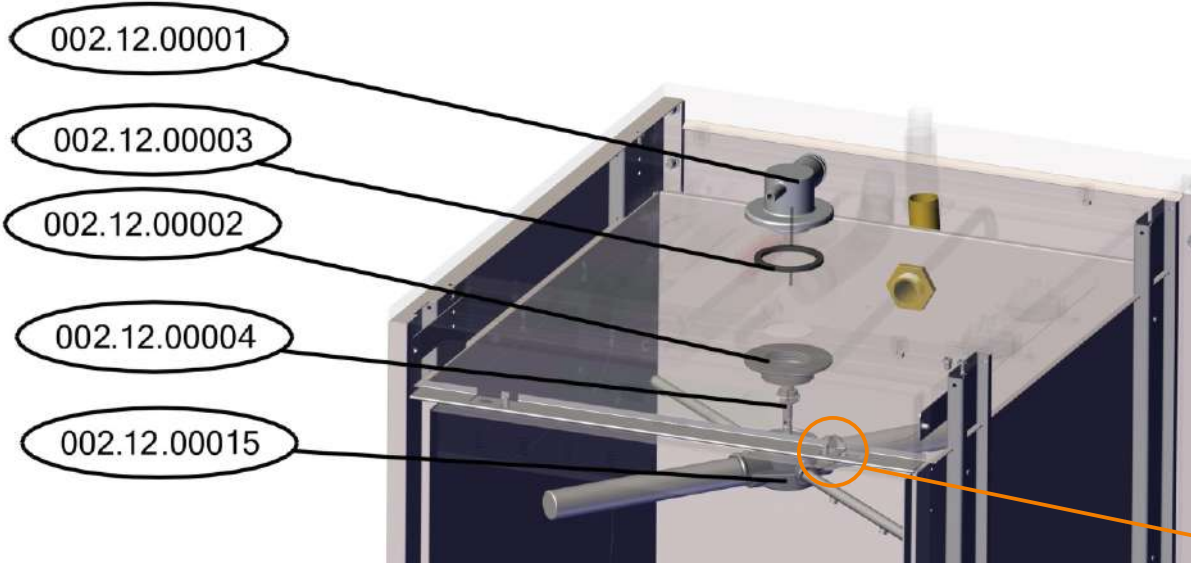

**MODEL 1200**

DESCRIPTION : RINSING WASHING CROSS - MODEL 1200

ITEM CODE : 002.12.00015

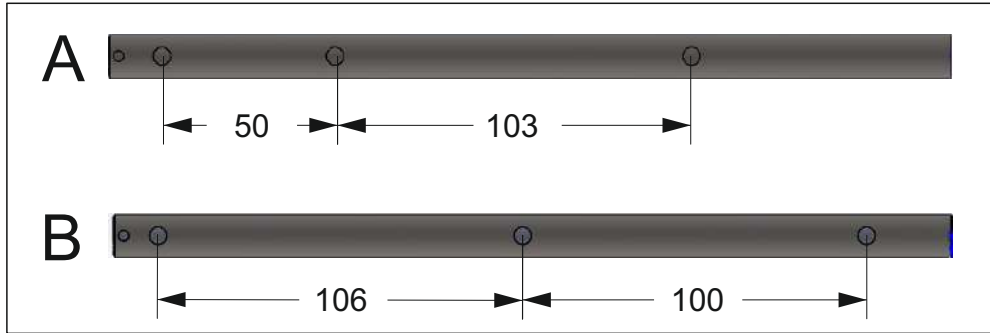

| PART ID          | DESCRIPTION                    | QTY |
|------------------|--------------------------------|-----|
| 002.15.00085     | RINSING-WASHING CROSS BASE     | 1   |
| 002.12.00017     | INOX WASH PIPE MODEL 1200      | 2   |
| 003.00.00579     | INOX SCREW M 4 X 10 mm         | 2   |
| 002.12.00016-A-B | RINSING ARM A AND B            | 1+1 |
| 002.00.00145     | CAP FOR RINSE ARM              | 2   |
| 001.00.00073     | INOX SCREW 2.9x10              | 2   |
| 003.00.00580     | INOX MACHINE SCREW M 4 x 10 mm | 2   |
| 002.35.00026     | TEFLON D18x10                  | 2   |
| 002.11.00008     | SPRAYER FOR RINSING ARM        | 6   |

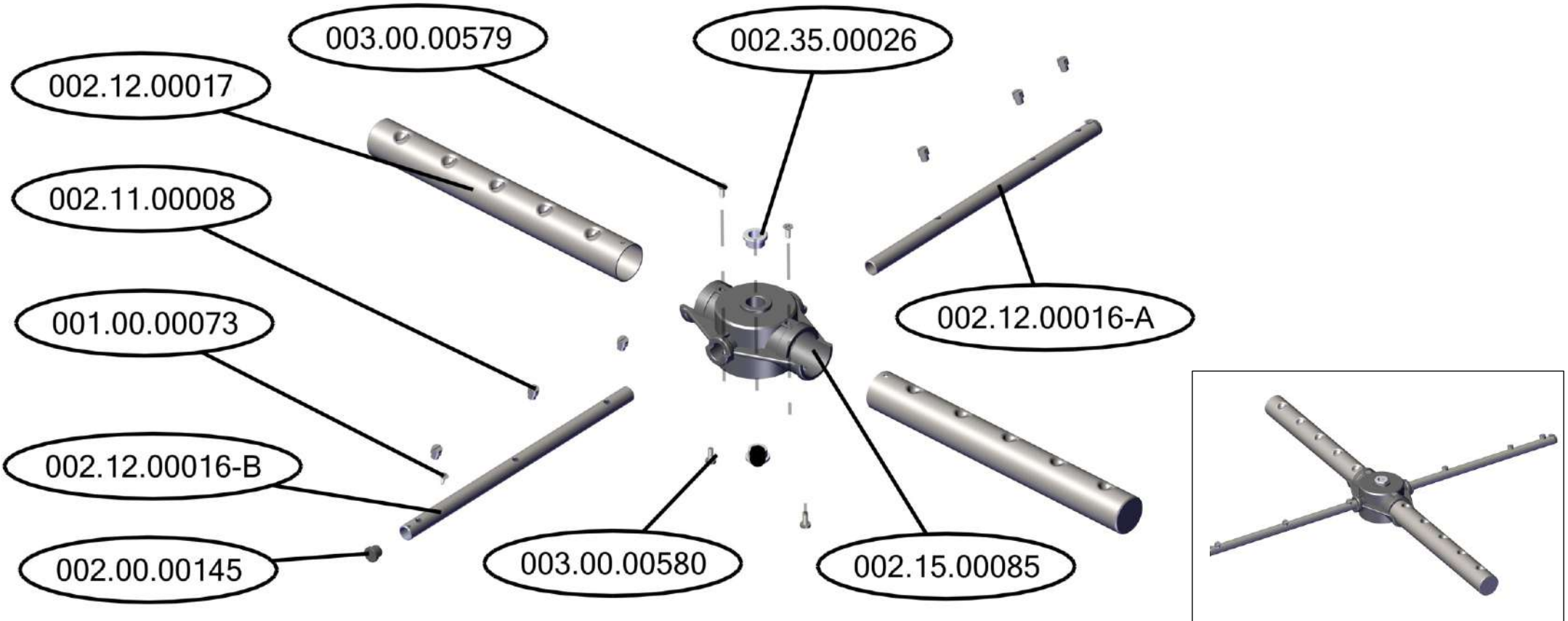

### MODEL 1200

DESCRIPTION : ELECTROMECHANICAL EQUIPMENT -BACK

ITEM CODE : -

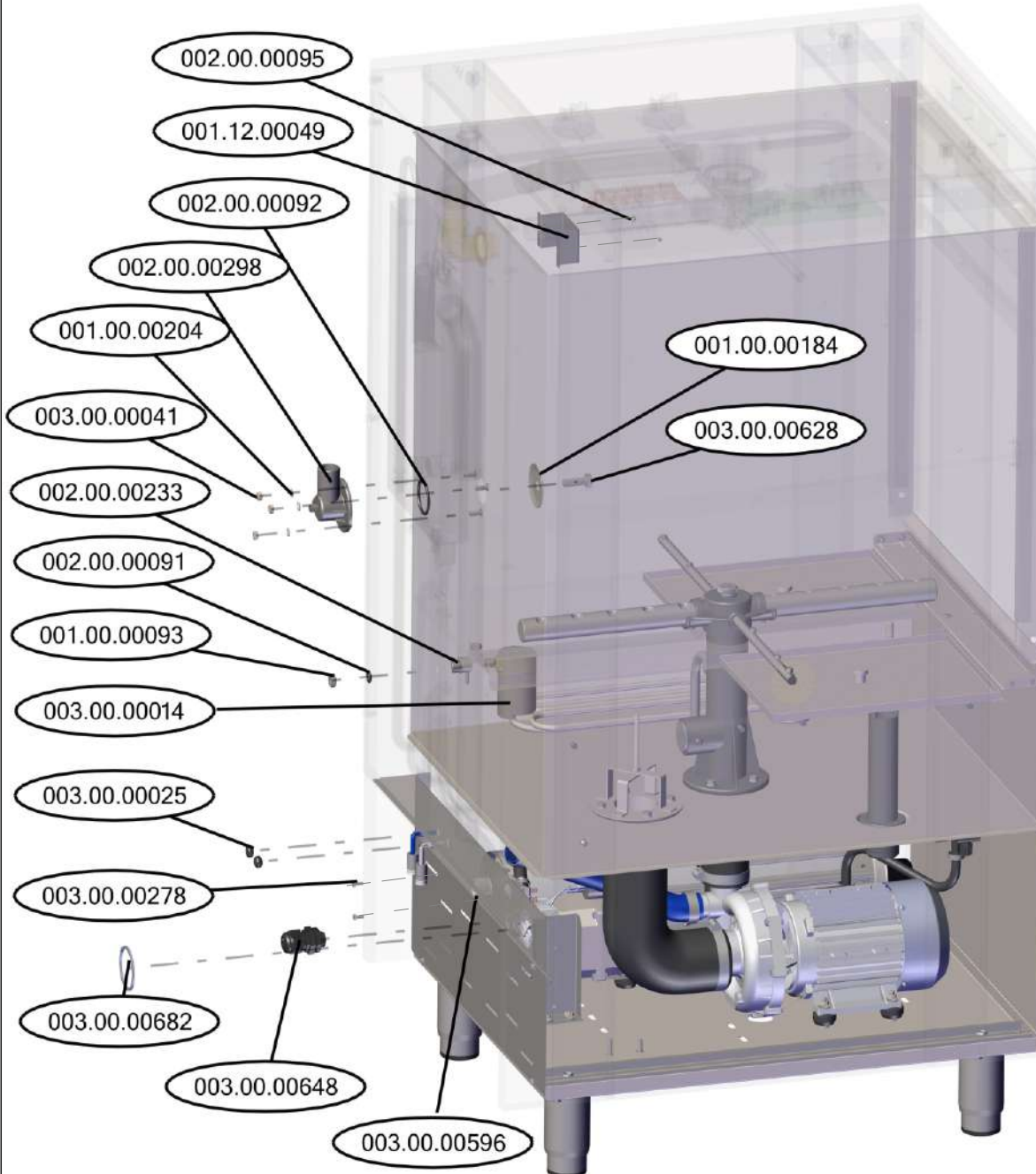

| PART ID      | DESCRIPTION                     | QTY |
|--------------|---------------------------------|-----|
| 001.12.00049 | INOX COVER FOR STEAM EXIT       | 1   |
| 002.00.00095 | INOX M4 NUT                     | 2   |
| 002.00.00298 | PLASTIC BT BASE                 | 1   |
| 001.00.00204 | LOCK WASHER Ø6                  | 3   |
| 003.00.00041 | NUT M6 (GALV)                   | 3   |
| 001.00.00184 | INOX PLATE D58                  | 1   |
| 003.00.00628 | INOX HEX BOLT M10X30            | 1   |
| 002.00.00233 | DETERGENT TANK INJEKTOR 4-6mm   | 1   |
| 003.00.00014 | PRESSOSTAT CHAMBER              | 1   |
| 002.00.00091 | O RING 3 X 10,5                 | 1   |
| 001.00.00093 | NUT M10 INOX                    | 1   |
| 003.00.00025 | CABLE RUBBER PROTECTOR          | 2   |
| 003.00.00596 | WATER INPUT VALVE 90° (50-440V) | 1   |
| 003.00.00278 | GALV HEX BOLD M4X10             | 2   |
| 003.00.00682 | PLASTIC CABLE PROTECTOR-1200    | 1   |
| 003.00.00648 | CABLE GLAND PG 21               | 1   |



**MODEL 1200**

DESCRIPTION : SURFACE FILTERS

ITEM CODE : -

| PART ID      | DESCRIPTION                       | QTY    |
|--------------|-----------------------------------|--------|
| 001.12.00025 | FILTER SUPPORT - MIDDLE           | 1      |
| 001.00.00110 | DOMED CAP NUT M6                  | 2      |
| 001.00.00247 | FRONT COVER SCREW INOX M6 X 25 mm | 1      |
| 001.12.00024 | FILTER SUPPORT - FRONT            | 1      |
| 002.00.00095 | INOX NUT M4                       | 2      |
| 001.12.00032 | SURFACE FILTER - COMPLETE         | 4      |
| 001.15.00153 | INOX KNOB                         | 1/PART |
| 003.00.00242 | INOX HEX SCREW M6X12              | 1/PART |

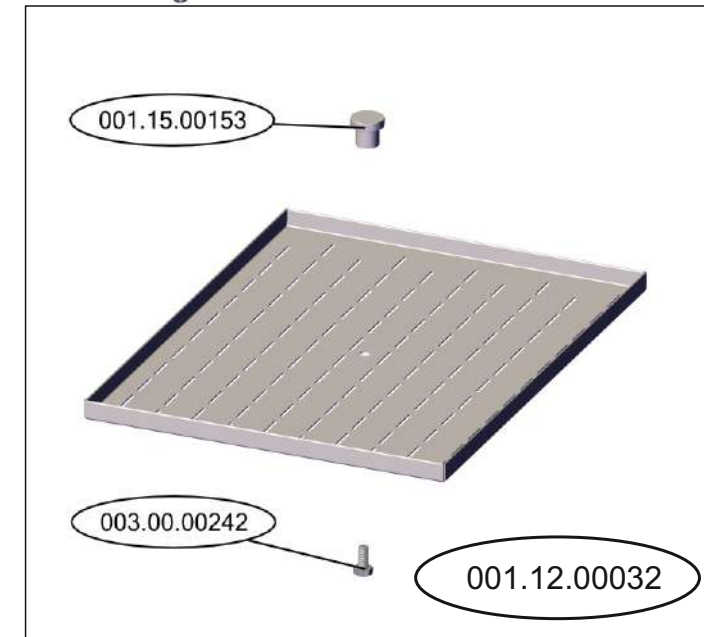
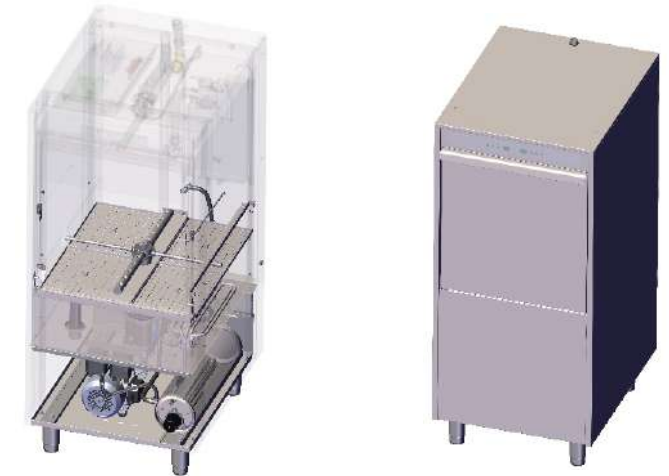
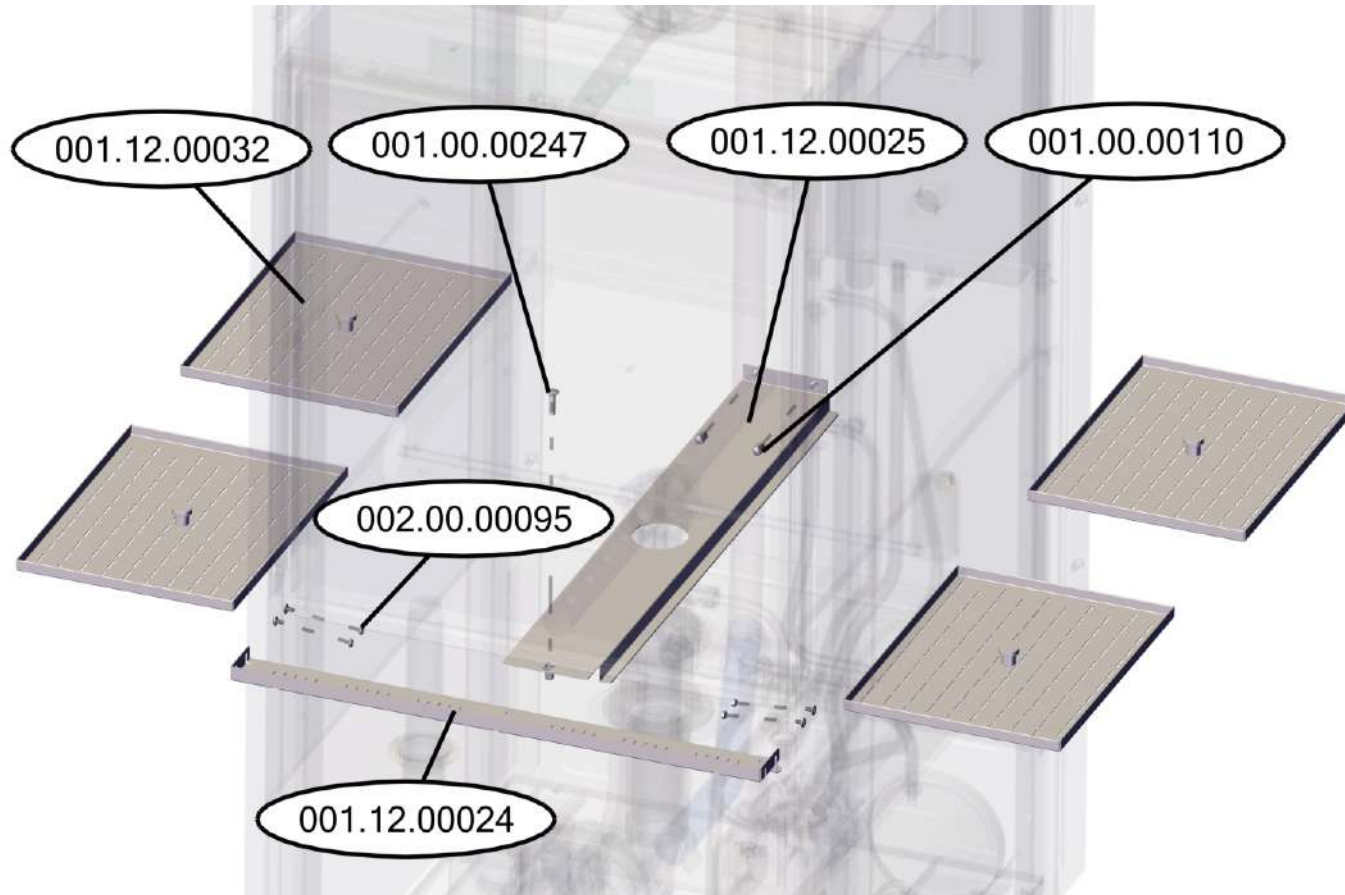

# MODEL 1200

DESCRIPTION : ELECTROMECHANICAL EQUIPMENT - BOTTOM1

ITEM CODE : -

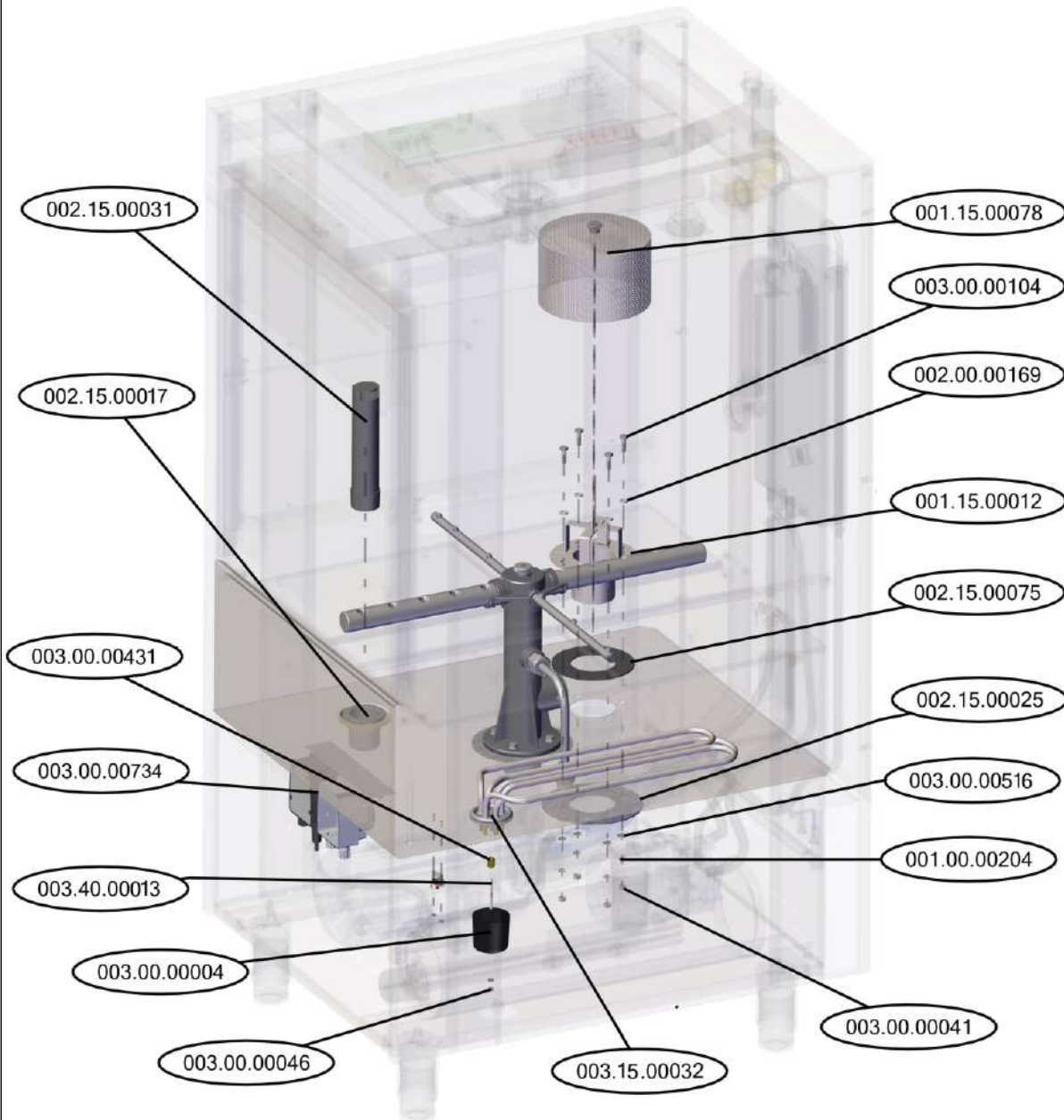

| PART ID      | DESCRIPTION                              | QTY |
|--------------|--|-----|
| 002.15.00031 | DRAIN & OVERFLOW PIPE A 1500             | 1   |
| 002.15.00017 | DRAIN & OVERFLOW PLASTIC BASE - COMPLETE | 1   |
| 001.15.00078 | PUMP FILTER TURBO 1500 - COMPLETE        | 1   |
| 003.00.00104 | INOX HEX BOLD M6X20                      | 4   |
| 002.00.00169 | TEFLON 12-6-2                            | 4   |
| 001.15.00012 | BASE FOR TANK FILTER                     | 1   |
| 002.15.00075 | TANK FILTER BASE RUBBER GASKET           | 1   |
| 002.15.00025 | RETAINING PLATE FOR FILTER               | 1   |
| 003.0.00516  | WASHER GALVANISED D6x18                  | 4   |
| 001.00.00204 | LOCK WASHER D6                           | 4   |
| 003.00.00041 | NUT M6 GALVANISED                        | 4   |
| 003.15.00032 | TANK HEATING ELEMENT                     | 1   |
| 003.00.00570 | TANK HEATING ELEMENT RETAINING BRACKET   | 1   |
| 001.00.00204 | LOCK WASHER D6                           | 1   |
| 00M.00.00041 | NUT M6 GALVANISED                        | 1   |
| 003.00.00431 | HEATING ELEMENT NUT 13mm M4 - M6         | 1   |
| 003.40.00013 | THREADED ROD M4x45                       | 1   |
| 003.00.00004 | HEATER ELEMENT COVER                     | 1   |
| 003.00.00046 | NUT M4 GALVANISED                        | 2   |
| 003.00.00734 | DETERGENT & RINSE-AID PUMP KIT FOR MODEL | 1   |

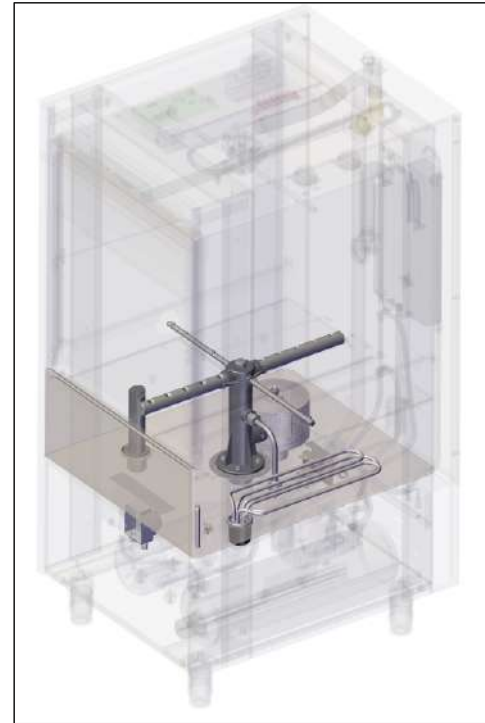

### MODEL 1200

DESCRIPTION : ELECTROMECHANICAL EQUIPMENT - BOTTOM2

ITEM CODE : -

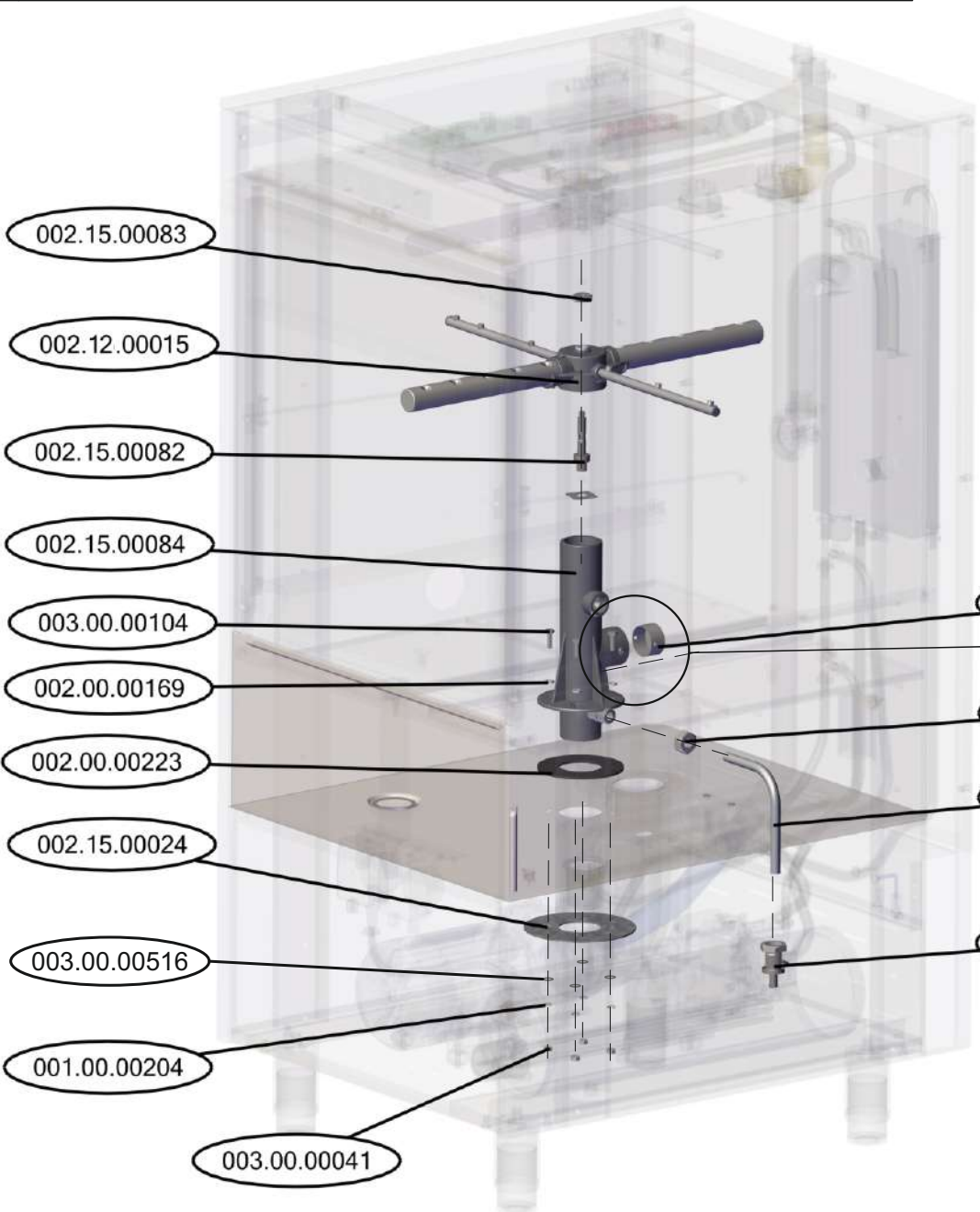

| PART ID      | DESCRIPTION                     | QTY |
|--------------|---------------------------------|-----|
| 002.15.00083 | INOX RETAINING NUT D25X7 M8     | 1   |
| 002.12.00015 | WASH&RINSE CROSS A1200 COMPLETE | 1   |
| 002.15.00082 | INOX AXLE Φ20M8 TURBO 1500 EVO  | 1   |
| 002.15.00084 | WASH - RINSE BASE TURBO 1500    | 1   |
| 003.00.00104 | INOX HEX BOLD M6X20             | 4   |
| 002.00.00169 | TEFLON 12-6-2                   | 4   |
| 002.00.00223 | RUBBER GASKET Φ109X54X3         | 1   |
| 002.00.00024 | RETAINING PLATE FOR BASE 1500   | 1   |
| 003.00.00516 | WASHER Φ6X18 GALVANISED         | 4   |
| 001.00.00204 | LOCK WASHER D6                  | 4   |
| 003.00.00041 | NUT M6 (GALVANISED)             | 4   |
| 001.12.00047 | BUTTOM WASH BASE PLUG           | 1   |
| 003.00.00441 | INOX HEX BOLD M4X60             | 1   |
| 002.00.00140 | LOCK WASHER INOX Φ4             | 1   |
| 002.00.00295 | INOX NUT M4                     | 1   |
| 002.00.00144 | RINSE PIPE RETAINING NUT        | 1   |
| 002.12.00018 | RINCE PIPE INOX 1200            | 1   |
| 002.00.00083 | RINSE BASE TU-KN - COMPLETE     | 1   |

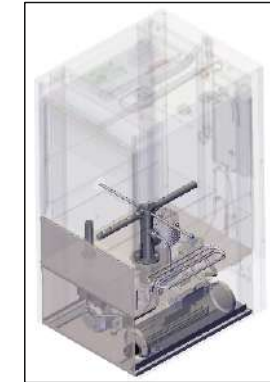
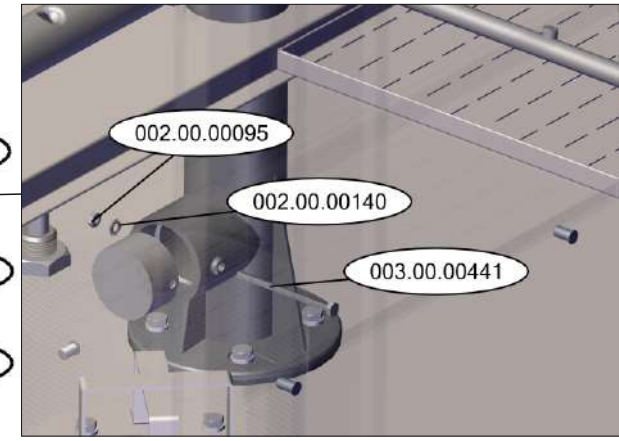

### MODEL 1200

DESCRIPTION : DETERGENT AND RINSE AID PUMP KIT MODEL 1200

ITEM CODE : 003.00.00734

| PART ID      | DESCRIPTION                              | QTY |
|--------------|--|-----|
| 001.12.00033 | BRACKET FOR PERISTALTIC PUMPS MODEL 1200 | 1   |
| 002.00.00195 | BALANCE F15x20                           | 2   |
| 002.00.00242 | FILTER PLASTIC FOR RINSE AID VALVE       | 2   |
| 003.00.00046 | NUT GALVANISED M4                        | 6   |
| 003.00.00140 | TUBO TRANSPARENT 4x6                     | -   |
| 003.00.00487 | TUBO PVC BLUE 4x6                        | -   |
| 003.00.00684 | PERISTALTIC DETERGENT PUMP SEKO          | 1   |
| 003.00.00687 | PERISTALTIC RINSE AID PUMP SEKO          | 1   |
| 002.00.00162 | LOCK WASHER M4                           | 6   |
| 001.00.00280 | WASHER $\Phi$ 4X10                       | 6   |

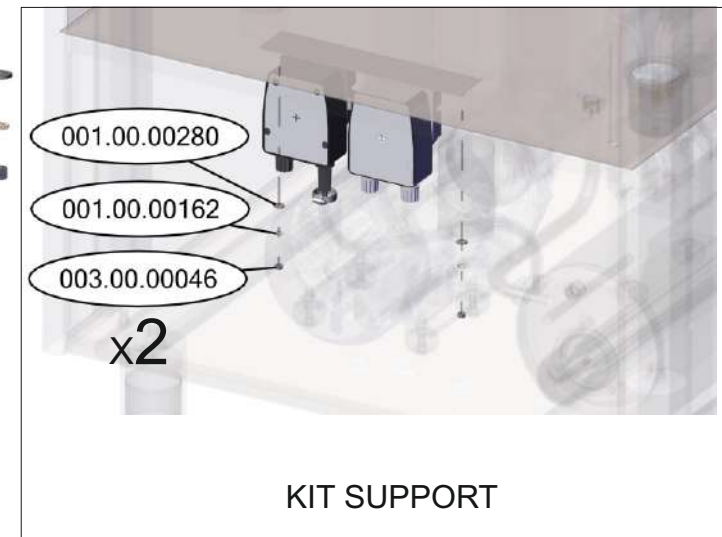
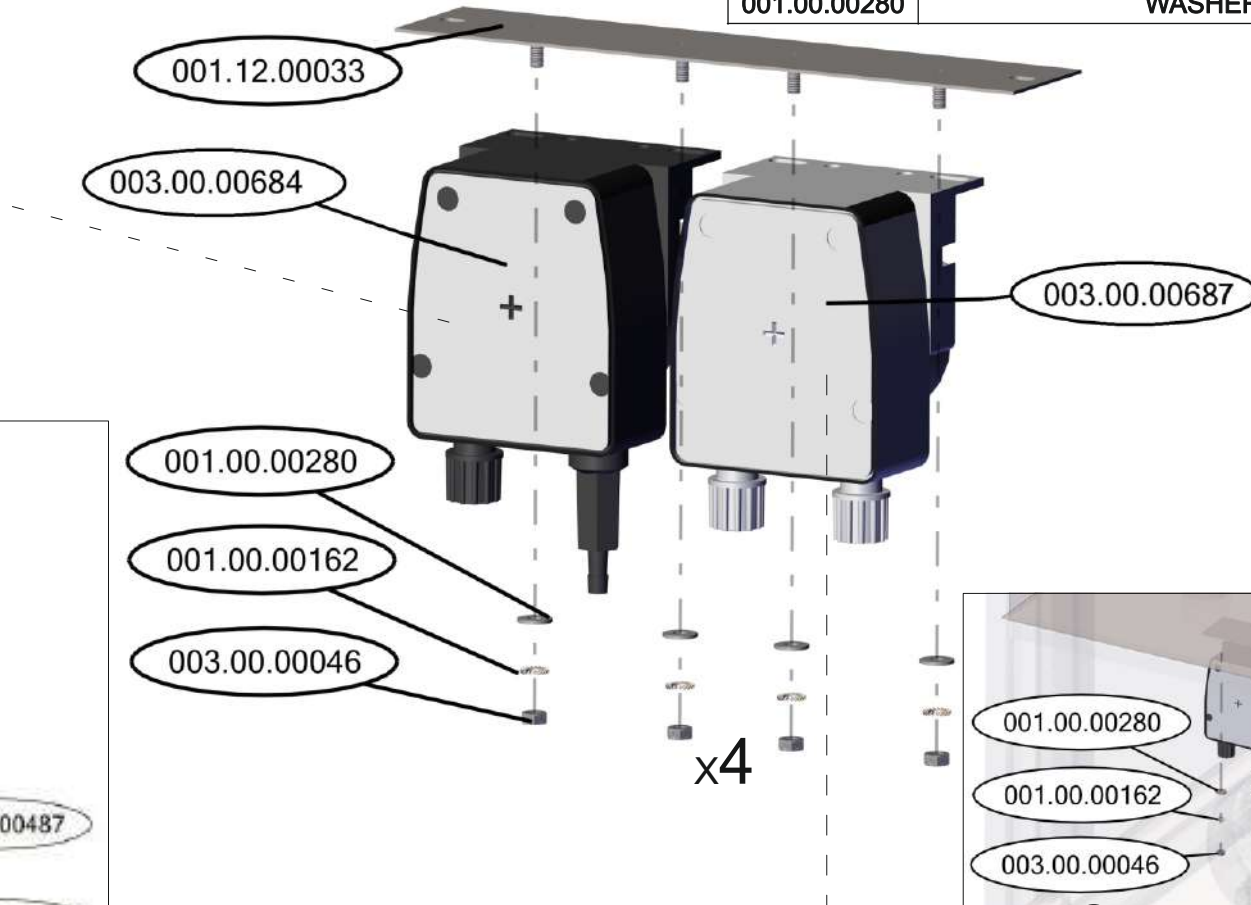
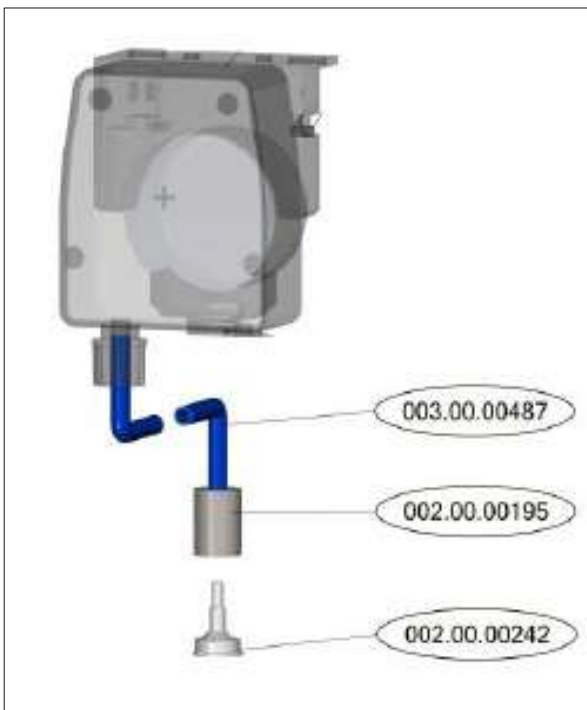
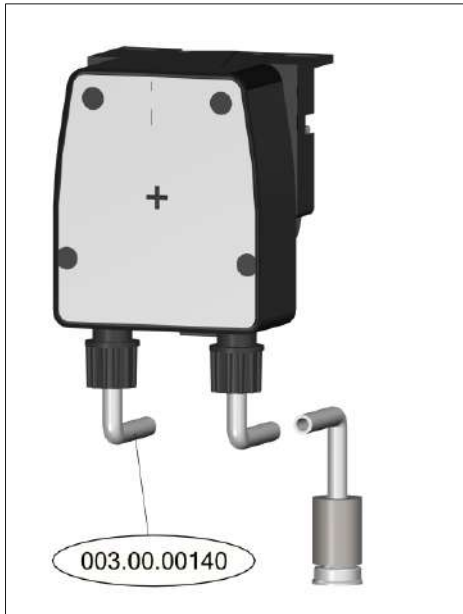

# MODEL 1200

DESCRIPTION : ELECTROMECHANICAL EQUIPMENT - BOTTOM - BASE

ITEM CODE :

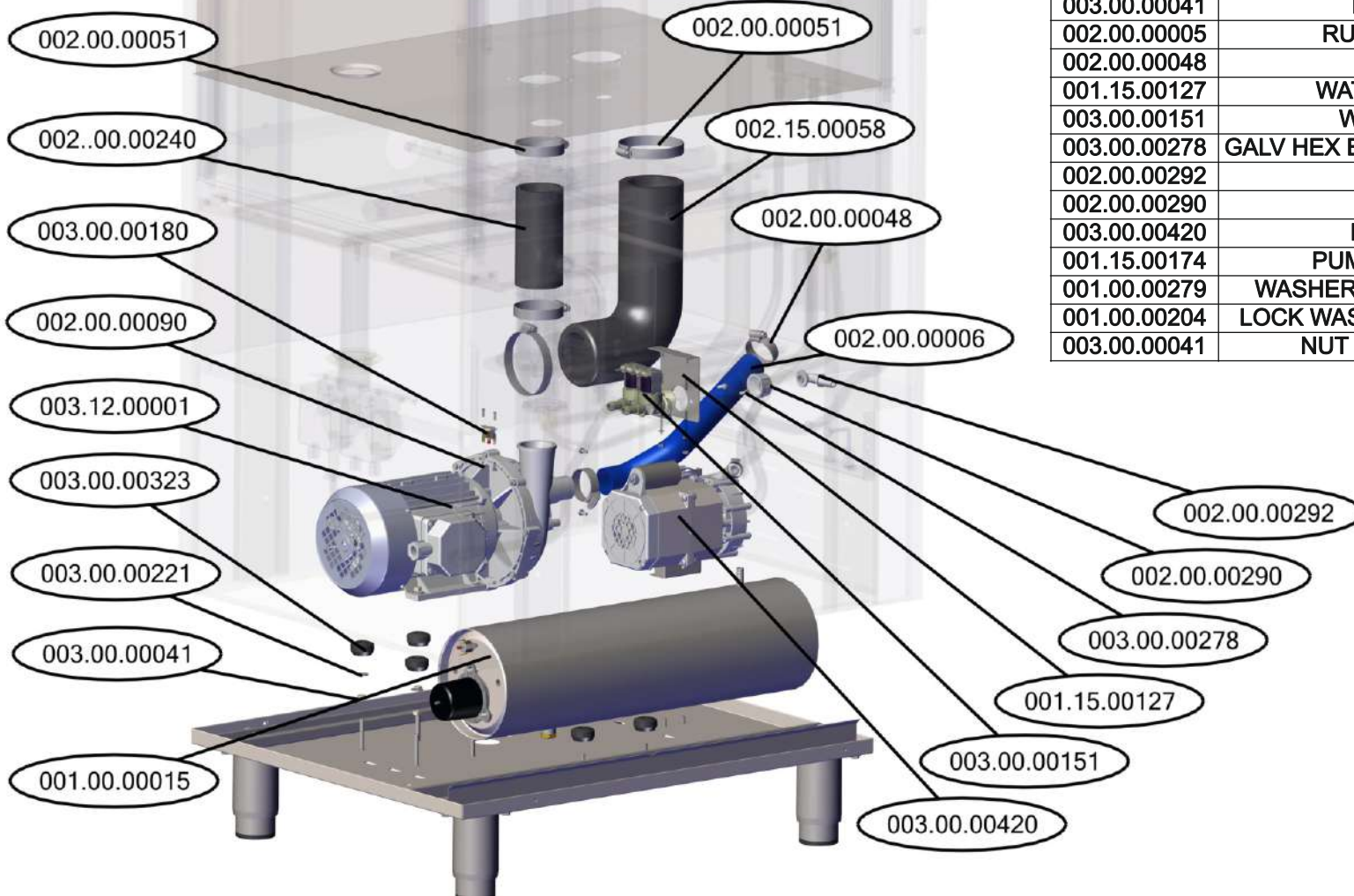

| PART ID      | DESCRIPTION                               | QTY |
|--------------|---|-----|
| 003.12.00001 | PUMP 1,2HP-230V-50Hz                      | 1   |
| 003.00.00323 | KOPLER D8-D31 (PUMP SUPPORT)              | 4   |
| 003.00.00221 | WASHER INOX D6X18 (PUMP SUPPORT)          | 8   |
| 003.00.00041 | NUT M6 (PUMP SUPPORT)                     | 8   |
| 002.00.00240 | PUMP HOSE 51x61 - 1200                    | 1   |
| 002.15.00058 | PUMP INLET HOSE - 1200                    | 1   |
| 002.00.00051 | CLAMP 60-80                               | 4   |
| 003.00.00180 | THERMOFUSE BOILER 105°C                   | 1   |
| 002.00.00090 | NUT M3                                    | 2   |
| 006.15.00013 | BOILER 230V SF 6KW (A1200 230/400)        | 1   |
| 003.00.00323 | KOPLER D8-D31 (BOILER SUPPORT)            | 2   |
| 003.00.00221 | WASHER Ø6X18 (BOILER SUPPORT)             | 2   |
| 001.00.00204 | LOCK WASHER D6 (BOILER SUPPORT)           | 2   |
| 003.00.00041 | NUT M6 (BOILER SUPPORT)                   | 2   |
| 002.00.00005 | RUBBER HOSE FLEXIBLE 32X325               | 1   |
| 002.00.00048 | CLAMP 25-40                               | 2   |
| 001.15.00127 | WATER VALVE SUPPORT - SINGLE              | 1   |
| 003.00.00151 | WATER INPUT VALVE DOUBLE                  | 1   |
| 003.00.00278 | GALV HEX BOLD M4X10 (WATER VALVE SUPPORT) | 2   |
| 002.00.00292 | NIPPLE INPUT - ANGLE                      | 1   |
| 002.00.00290 | FITTING 3/4"                              | 1   |
| 003.00.00420 | PUMP BOOSTER 230V/50Hz                    | 1   |
| 001.15.00174 | PUMP BOOSTER STEEL SUPPORT                | 1   |
| 001.00.00279 | WASHER D8×16 (PUMP BOOSTER SUPPORT)       | 2   |
| 001.00.00204 | LOCK WASHER D6 (PUMP BOOSTER SUPPORT)     | 2   |
| 003.00.00041 | NUT M6 (PUMP BOOSTER SUPPORT)             | 2   |





**MODEL 1200**

DESCRIPTION : EQUIPMENT

ITEM CODE : -



002.00.00109



001.00.00016

| PART ID      | DESCRIPTION   | QTY |
|--------------|---|-----|
| 001.00.00016 | FOOT SMALL M10<br>(MACHINE DELIVERED WITH THESE FOOT) | 4   |
| 002.00.00109 | INLET HOSE 1500mm - MOD40                             | 1   |
| 001.00.00250 | LEVELING FEET 1"3/4 304 120/170 M10X25                | 4   |
| 003.00.00727 | PLASTIC BASKET (XL) 500X600 FOR TRAY                  | 1   |
| 003.00.00728 | PLASTIC BASKET (XL) 500X600 FOR CUPS                  | 1   |

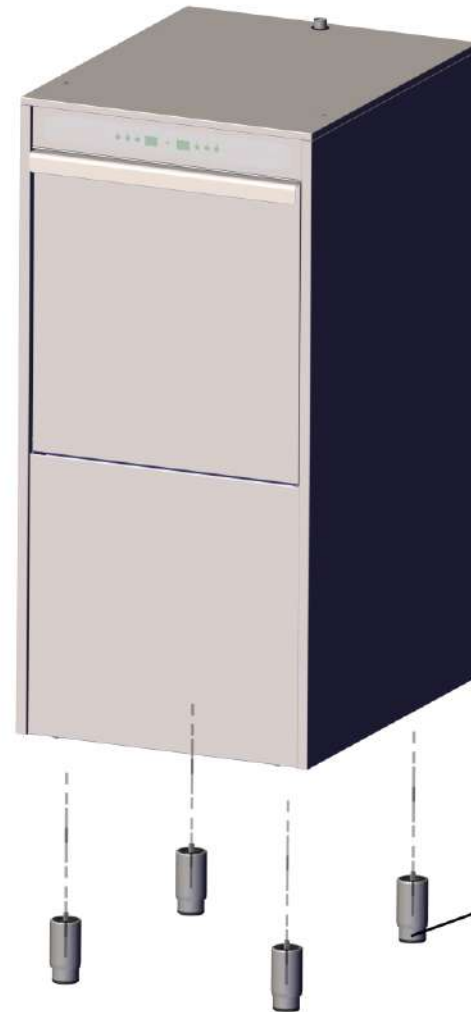

001.50.00250