

ITEM NO.	PART NUMBER	DESCRIPTION	VERGINA50/ QTY.
2	001.50.00048	FRONT COVER INOX V50	1
3	001.50.00046	DOOR COMPLETE V50 - K50	1
5	001.00.00045	TEFLON WASHER $\Phi$ 12,5 X 8 X 2,5	2
6	001.00.00051	DOOR SNAP SET	2
7	001.00.00213	INOX SCREW M4X15	2
8	001.00.00117	DOME NUT M4	2
9	002.00.00095	INOX NUT M4	2
10	002.00.00140	LOCK WASHER INOX $\Phi$ 4	2
11	001.00.00016	SMALL BLACK FOOT V500	4
12	001.50.00043-1	BACK COVER INOX V50 - K50	1
13	001.00.00221	PLASTIC GUIDE FOR DOOR AXLE	2
14	001.00.00048-M	DOOR LEFT SUPPORT AXLE M6X300	1
15	001.00.00048	DOOR RIGHT SUPPORT AXLE M6X300	1
16	001.00.00110	DOMED CAP NUT M6	2
17	001.00.00073	INOX SCREW 2,9 X 10	4
20	001.50.00015	UPPER COVER INOX V50 - K50	1

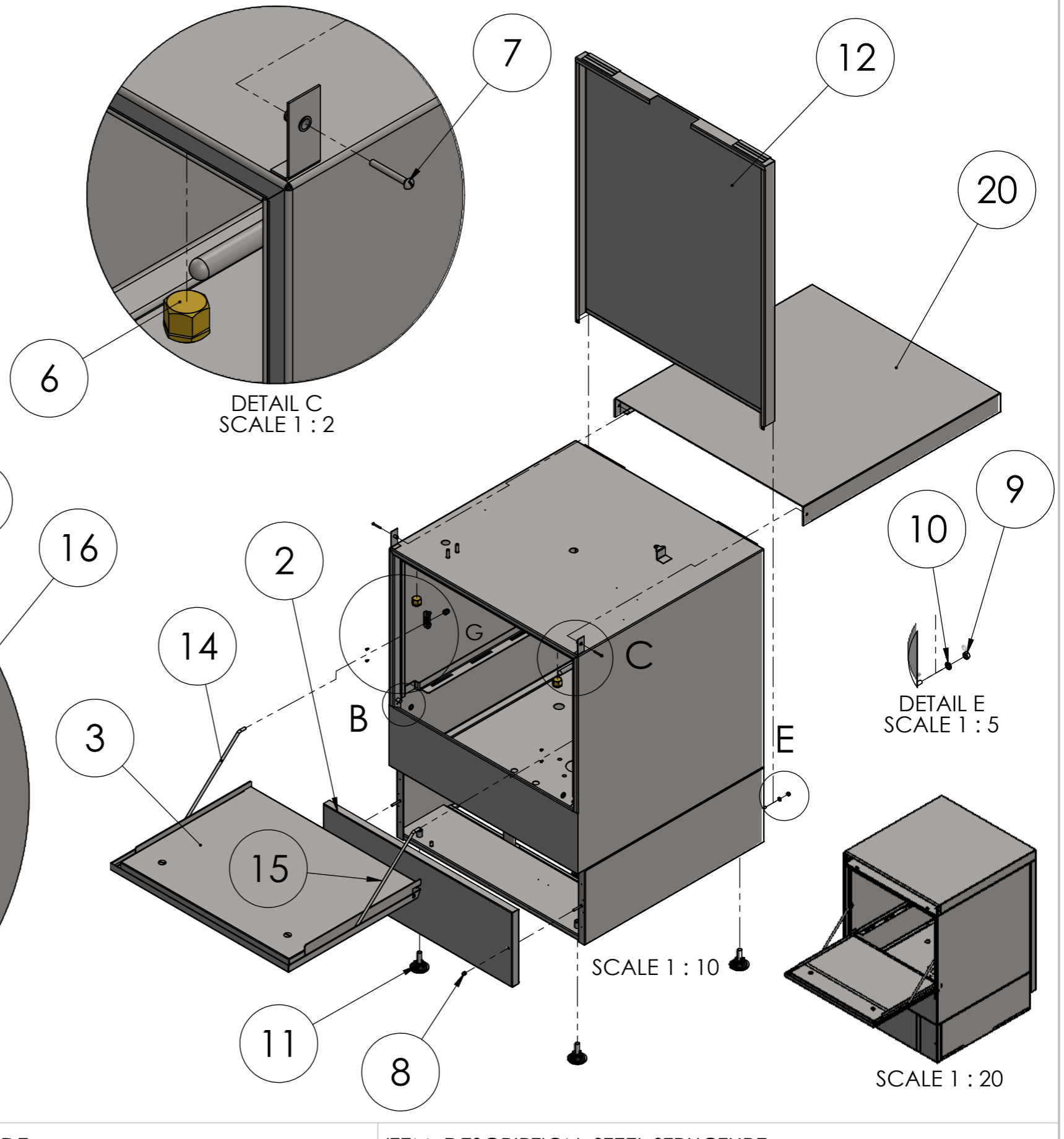

ITEM CODE:

ITEM DESCRIPTION: STEEL STRUCTURE

SERIES DESCRIPTION: UNDERCOUNTER

MODEL DESCRIPTION: V50

MODEL VERSION:VERGINA50 400V ~3N  
50/60Hz

MODEL CODE: 004.50.00010

PAGE: 1

REVISION: 0

ITEM NO.	PART NUMBER	DESCRIPTION	QTY.
3	001.00.00118	DOOR HANDLE COMPLETE V-K	1
4	002.00.00057	DOOR HANDLE PLASTIC FLANGE	2
10	003.00.00211	INOX COUNTERSUNK BOLT M8X30	2

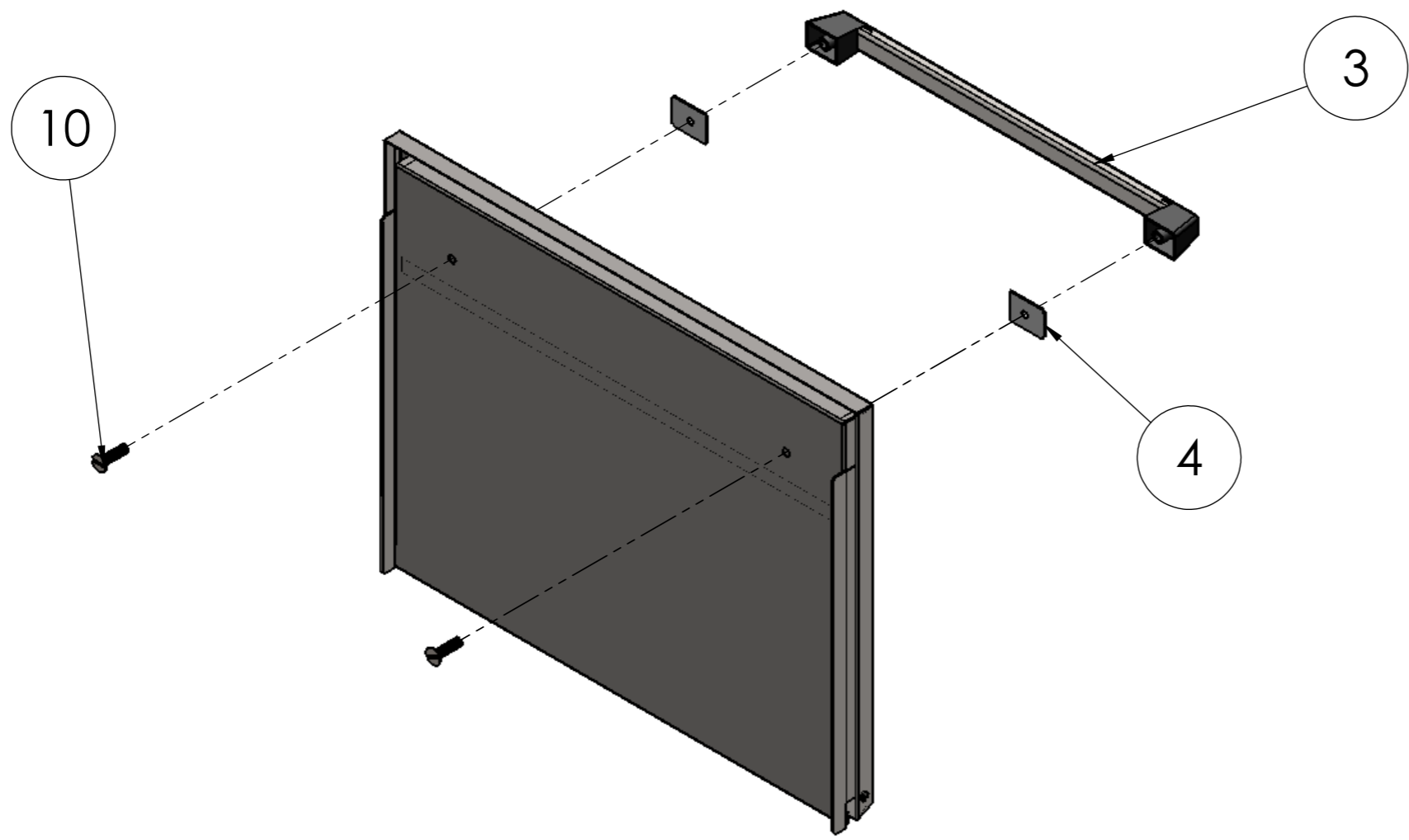

SCALE 1 : 5

SERIES DESCRIPTION: UNDERCOUNTER		MODEL DESCRIPTION: V50		ITEM CODE: 001.50.00046		ITEM DESCRIPTION: DOOR COMPLETE V50 - K50	
				MODEL VERSION: VERGINA50 400V~3N 50/60HZ		MODEL CODE:004.50.00010	
						PAGE: 1	
						REVISION: 0	

ITEM NO.	PART NUMBER	DESCRIPTION	VERGINA/QTY.
2	003.00.00494	CABLE PLASTIC CLAMP	2
3	002.00.00140	LOCK WASHER INOX Φ4	4
4	003.00.00046	NUT M4 (GALV)	4
5	003.50.00002	DISPLAY PANEL COMPLETE V50	1
6	006.50.00002	ELECTRICAL BOX COMPLETE 230V~N 50/60Hz	1

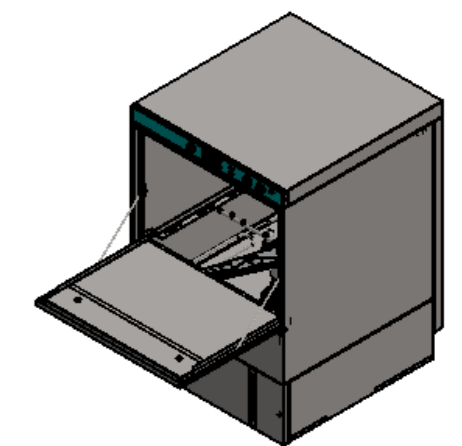
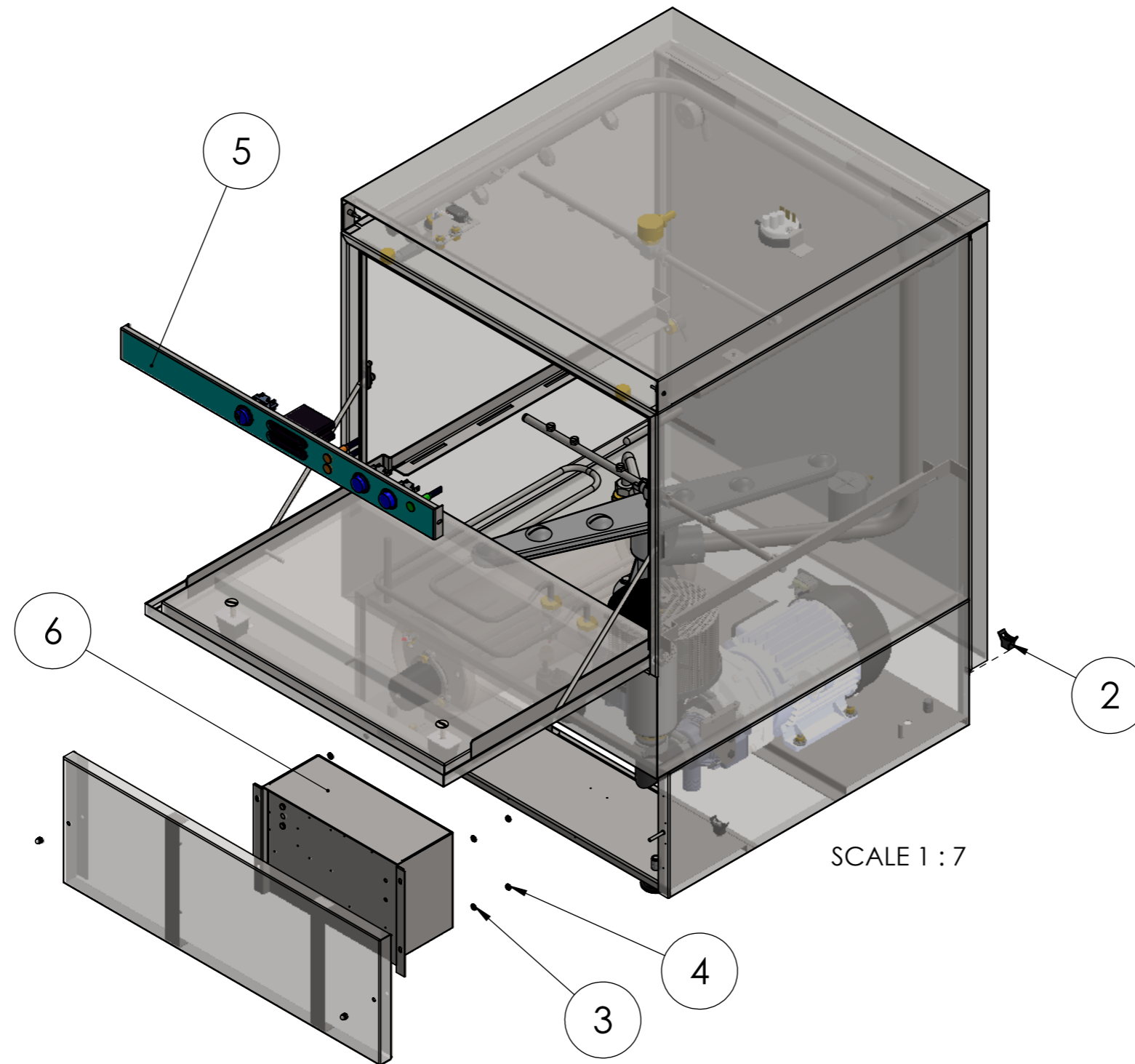

SCALE 1 : 20

ITEM CODE:

ITEM DESCRIPTION: ELECTRICAL EQUIPMENT

SERIES DESCRIPTION: UNDERCOUNTER

MODEL DESCRIPTION: V50

MODEL VERSION:VERGINA50 230V~N  
50/60Hz

MODEL CODE:004.50.00090

PAGE: 1

REVISION:

ITEM NO.	PART NUMBER	DESCRIPTION	QTY.
1	001.50.00044	SWITCH PANEL INOX V50	1
8	003.50.00009	MEMBRANE FOR VERGINA50	1
3	003.00.00505	THERMOMETER 2500mm	2
4	003.00.00564	SWITCH START ROUND TWO CONTACTS	2
5	003.00.00028	INDICATOR ORANGE	2
6	003.00.00176	INDICATOR GREEN	1
7	003.00.00563	SWITCH ON-OFF ROUND 4 CONT.	1

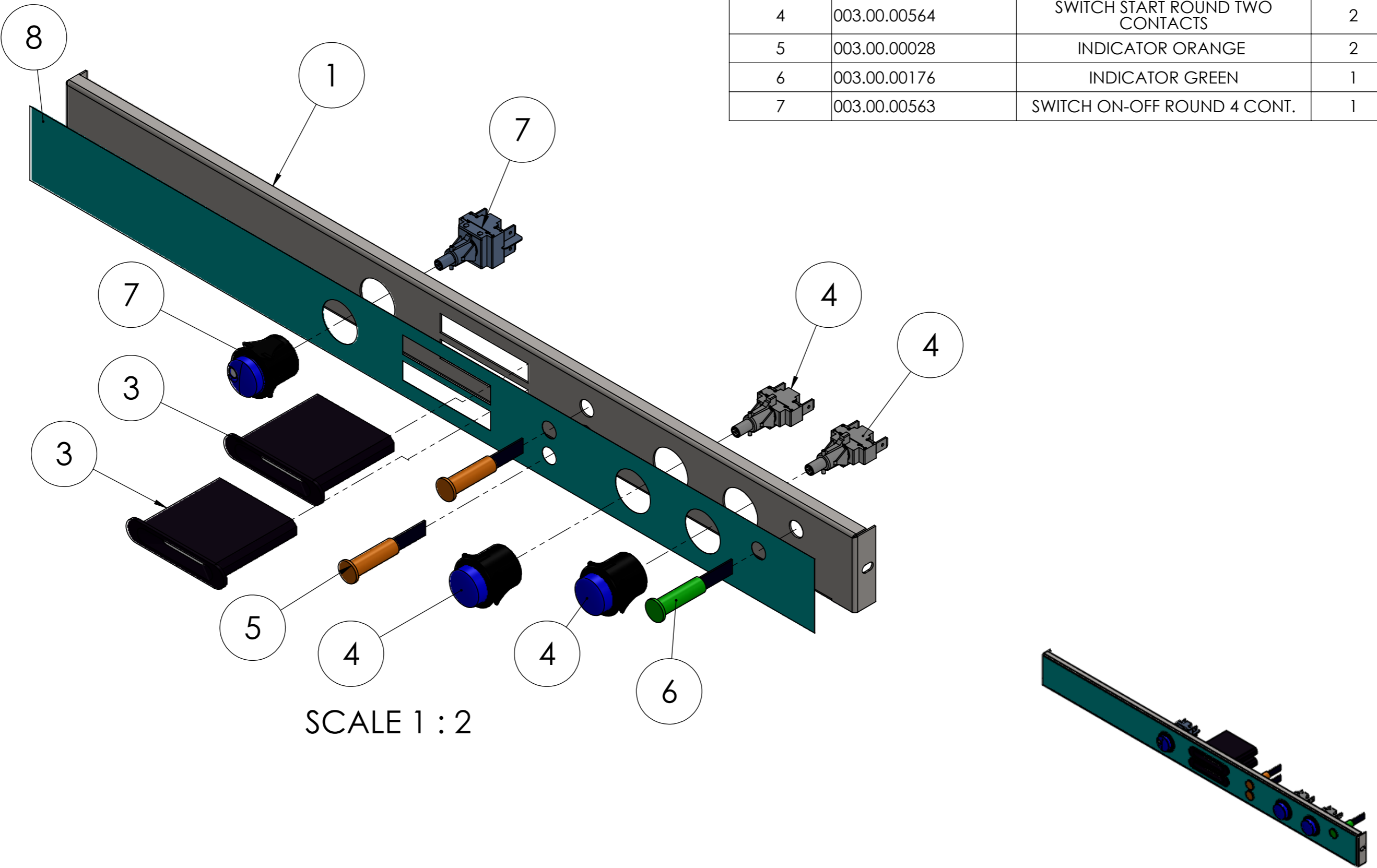

SCALE 1 : 2

SERIES DESCRIPTION: UNDERCOUNTER		MODEL DESCRIPTION: V50		ITEM CODE: 003.50.00002	ITEM DESCRIPTION: DISPLAY PANEL COMPLETE V50
		MODEL VERSION: VERGINA50 400V~3N 50/60Hz		MODEL CODE:004.50.00010	PAGE: 1
					REVISION: 0

ITEM NO.	PART NUMBER	DESCRIPTION	QTY.
3	003.00.00213	THERMOSTAT 0-90oC 1500mm	2
4	001.00.00076	GALVANIZED MACHINE SCREW M4 X 5	4
5	003.00.00056	MAGNETIC CONTACTOR	2
6	003.00.00046	NUT M4 (GALV)	2
7	003.00.00448	TIMER 120 SEC. Q.START	1
8	002.00.00090	GALV. BOLT M4X10	2
11	003.00.00030	POWER SUPPLY BOARD 6 CONN.	1

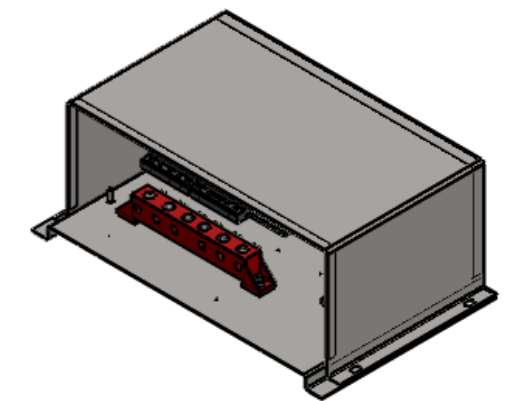
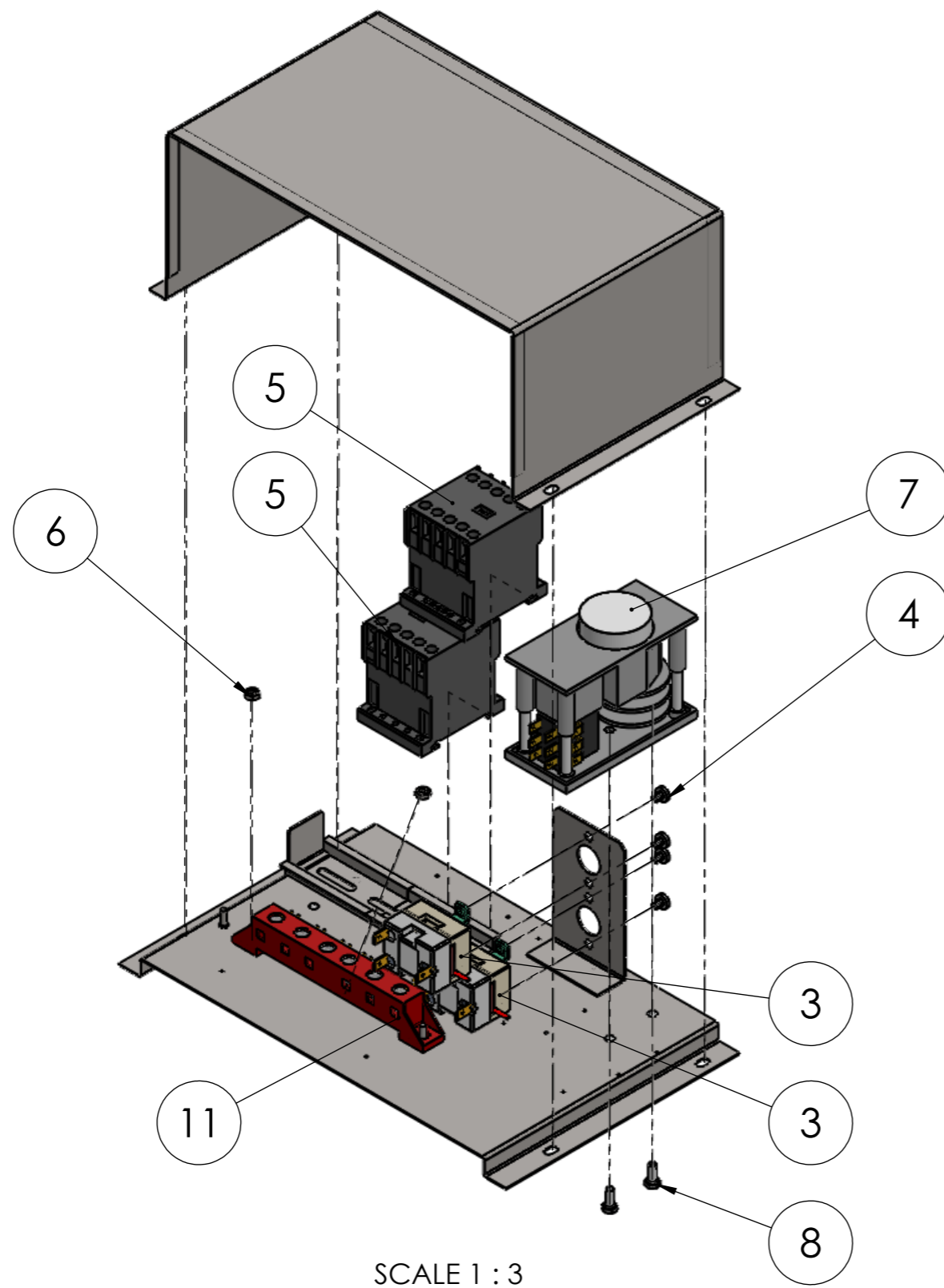

ITEM CODE: 006.50.00003

ITEM DESCRIPTION: ELECTRICAL BOX

SERIES DESCRIPTION: UNDERCOUNTER

MODEL DESCRIPTION: V50

MODEL VERSION: VERGINA 50 400V~  
3N 50/60Hz

MODEL CODE:004.50.00010

PAGE: 1

REVISION: 0

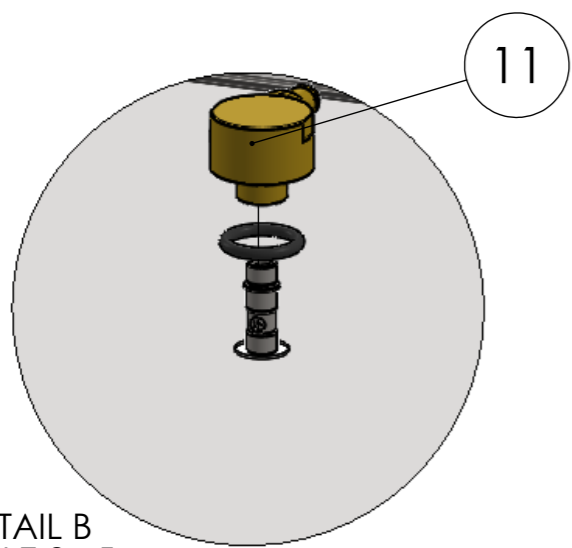

DETAIL B  
SCALE 2 : 5

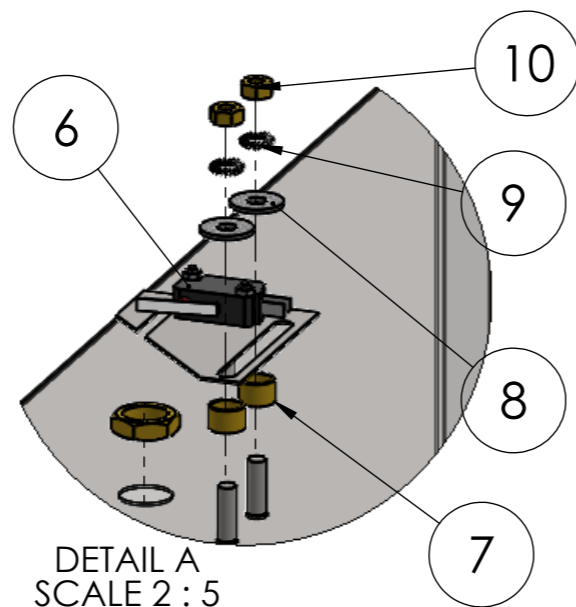

DETAIL A  
SCALE 2 : 5

ITEM NO.	PART NUMBER	DESCRIPTION	VERGINA/QTY.
5	003.00.00231	DOOR SWITCH MECH. PART	1
6	003.00.00426	DOOR SWITCH EL. PART 35-40-50 COMPLETE	1
7	003.00.00085	SPACER FOR DOOR SWITCH	2
8	003.00.00516	WASHER STEEL $\Phi 6 \times 18$	2
9	001.00.00204	GALVANIZED LOCK WASHER 6,4x11x0,7	2
10	003.00.00041	NUT M6 GALVANISED	2
11	002.35.00029	UPPER RINSING BASE COMPLETE	1
12	003.00.00033	PRESSOSTAT	1
13	003.00.00200	TAPPING SCREW 3.5X9.50	1
25	002.50.00026	RINSING ARM UP OR DOWN V-K	2
26	002.50.00004-1	LOCK NUT FOR RINSING ARM	2

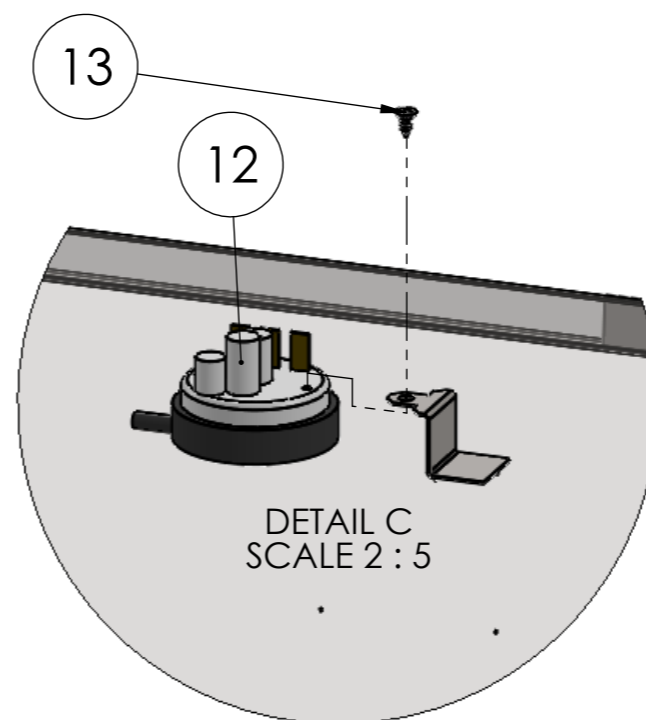
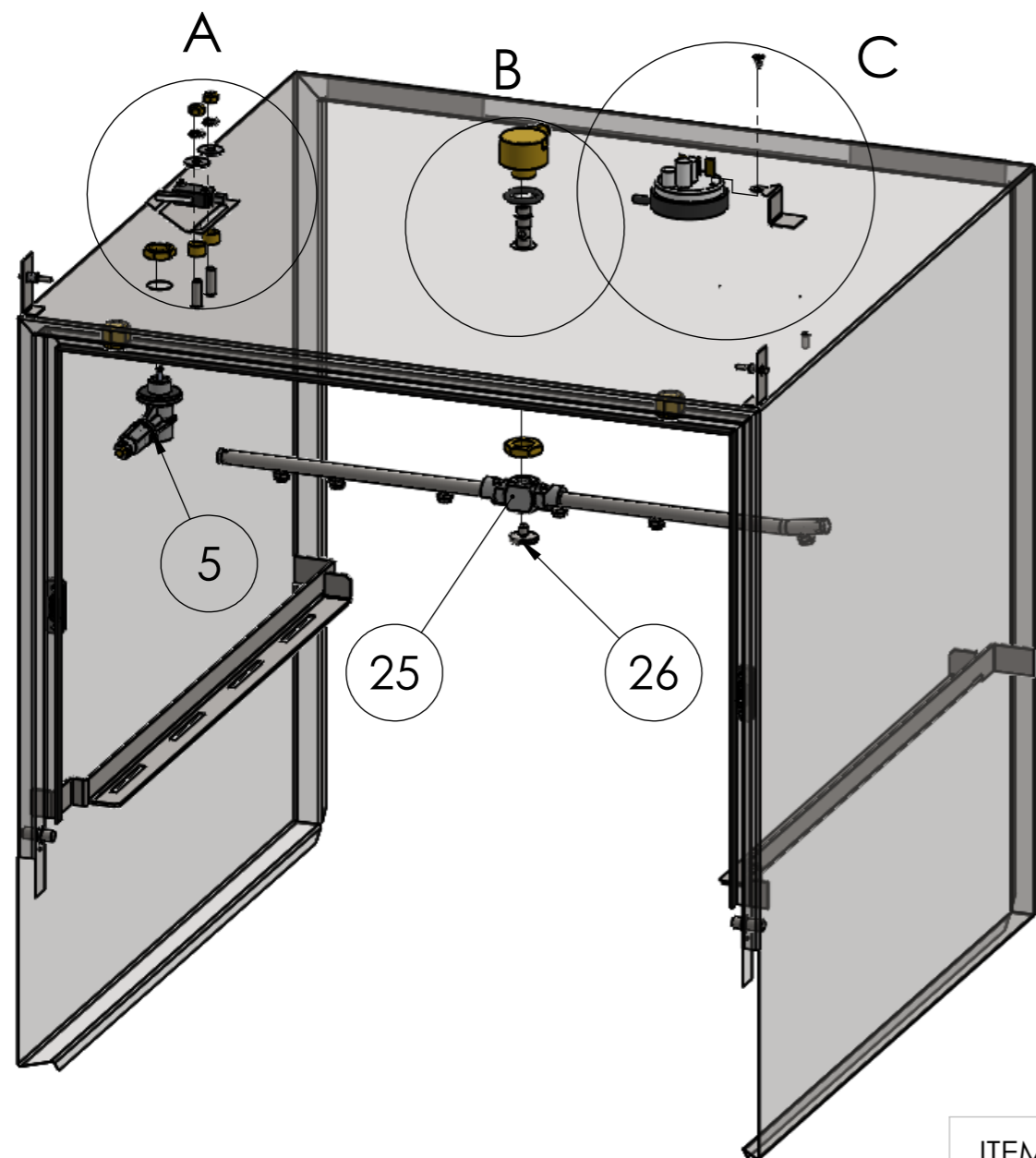

DETAIL C  
SCALE 2 : 5

ITEM CODE:

ITEM DESCRIPTION: MECHANICAL EQUIPMENT

SERIES DESCRIPTION: UNDERCOUNTER

MODEL DESCRIPTION: V50

MODEL VERSION: VERGINA50 400V~3N  
50/60Hz

MODEL CODE:004.50.00010

PAGE: 3

REVISION: 0

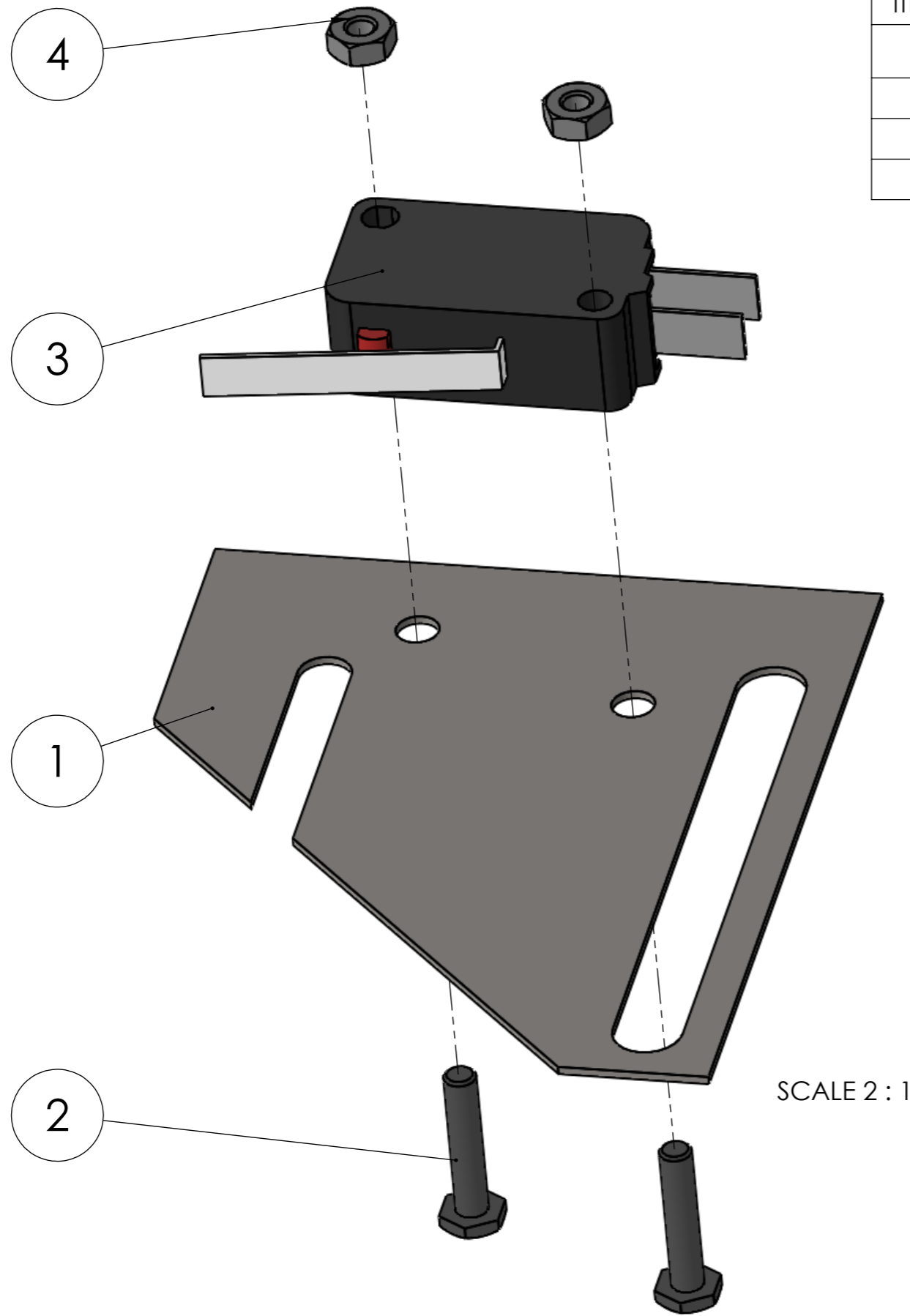

SCALE 2 : 1

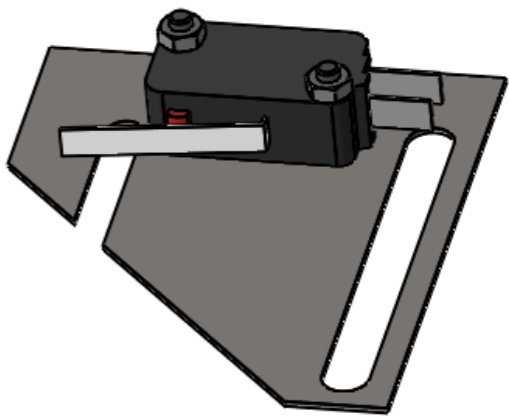

ITEM NO.	PART NUMBER	DESCRIPTION	VERGINA/QTY.
1	003.00.00077	BASE INOX FOR THE ELECTRICAL DOOR SWITCH	1
2	003.00.00065	GALV. HEX. BOLT M3X16	2
3	003.00.00069	DOOR MICRO SWITCH	1
4	002.00.00090	GALV. NUT M3	2

SERIES DESCRIPTION: UNDERCOUNTER

MODEL DESCRIPTION: VE50

ITEM CODE: 003.00.00426  
 MODEL VERSION:VERGINA50  
 400V~3N 50/60Hz

ITEM DESCRIPTION: DOOR SWITCH ELECTRICAL PART COMPLETE  
 MODEL CODE:004.50.00010

PAGE:

REVISION:

ITEM NO.	PART NUMBER	DESCRIPTION	VERGINA/QTY.
3	002.50.00036	WASHING BASE DOWN V-K COMPLETE	1
9	001.00.00204	GALVANIZED LOCK WASHER 6,4x11x0,7	4
10	003.00.00041	NUT M6 GALVANISED	4
16	002.00.00062	NUT 1/2	1
22	002.50.00016	FLOW CONTROL DISK FOR BASE V-K	1
23	002.11.00002	AXLE INOX FOR BASE DOWN V500	1
24	002.50.00006	LOWER WASHING ARM V50	1
25	002.50.00026	RINSING ARM UP OR DOWN V-K	2
26	002.50.00004-1	LOCK NUT FOR RINSING ARM	2
27	002.50.00022	RINSE PIPE INOX V-K	1
28	002.00.00144	RINSE PIPE RETAINING NUT	2
29	002.00.00091	ORING 3X10,5	2
52	002.50.00018	WASHING UPPER SYSTEM INOX SUPPLY PIPE	1
53	002.50.00017	CONNECTOR WASHING SYSTEM PLASTIC	1
54	002.50.00019	WASHING UPPER SYSTEM INOX UP-LEFT	1
55	002.50.00020	WASHING UPPER SYSTEM INOX UP- RIGHT	1
57	003.00.00104	INOX HEX BOLT M6X20	4
58	002.00.00169	TEFLON 12-6-2	4

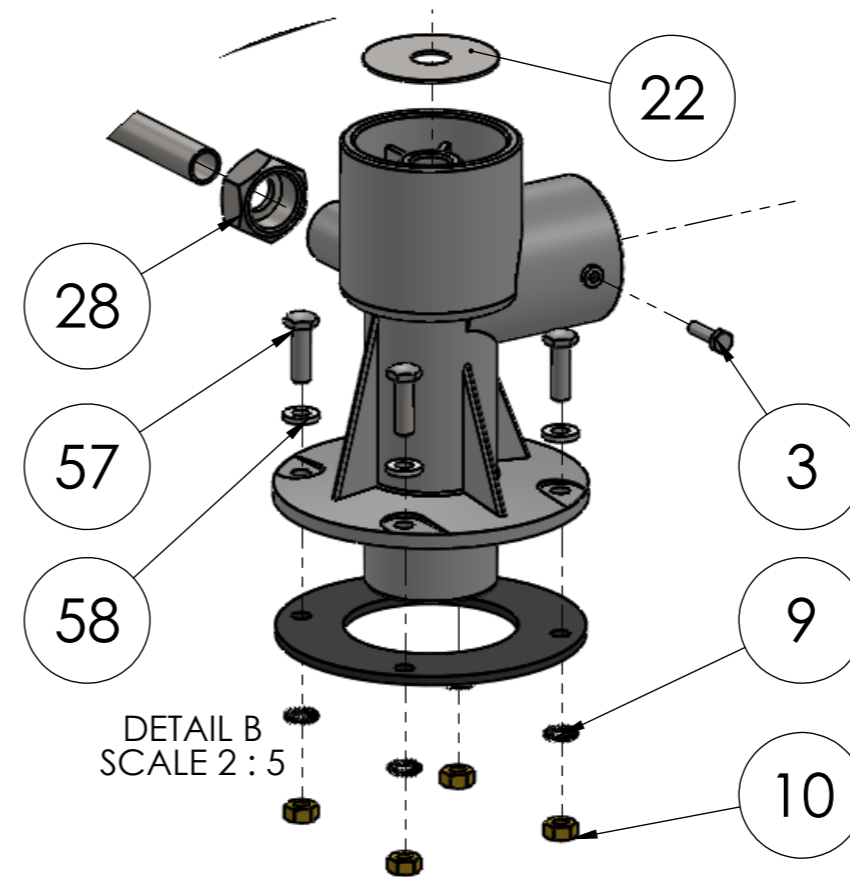
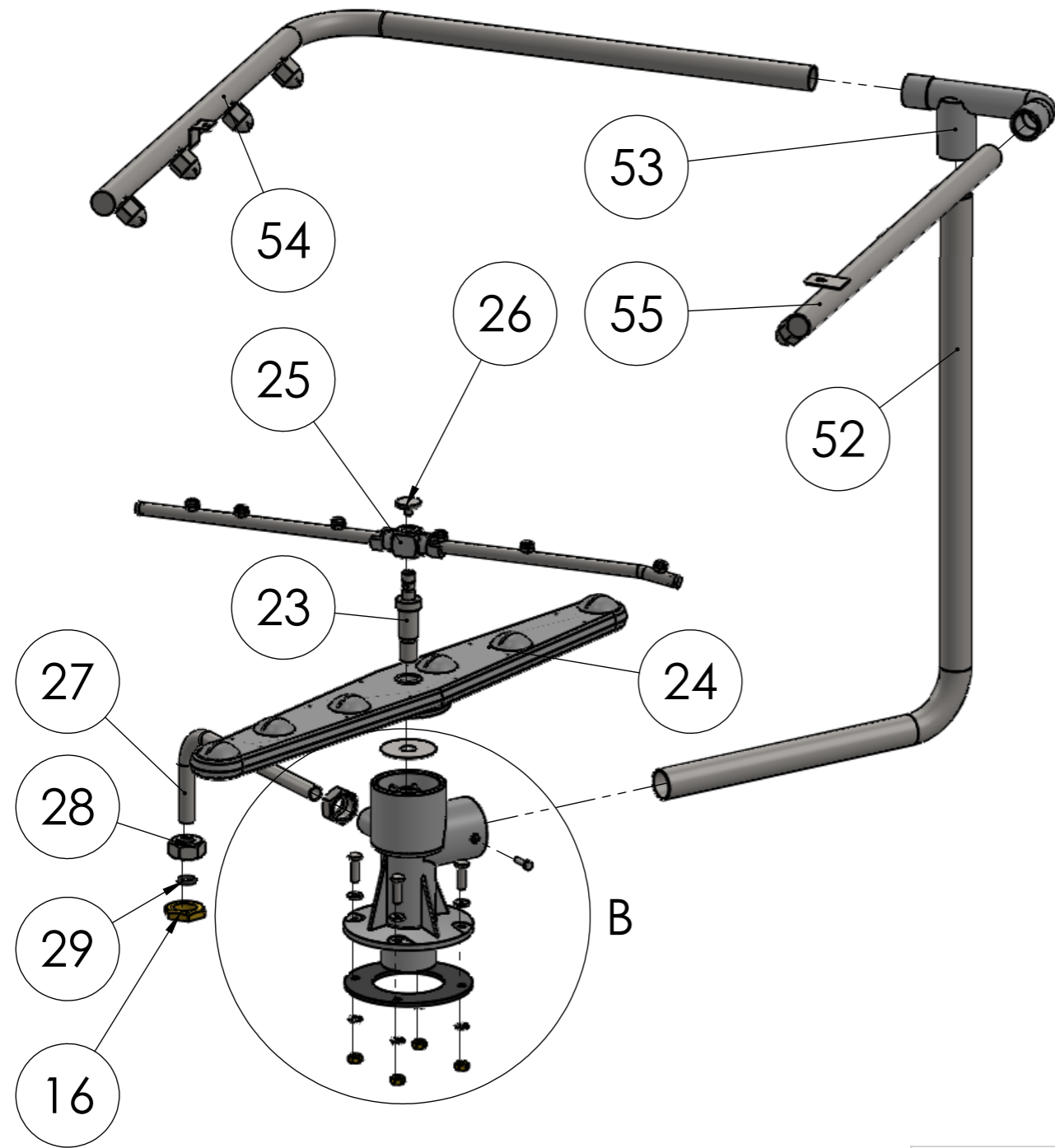

SERIES DESCRIPTION: UNDERCOUNTER	MODEL DESCRIPTION: V50	ITEM CODE:	ITEM DESCRIPTION: MECHANICAL EQUIPMENT		
		MODEL VERSION: VERGINA50 400V ~ 3N 50/60Hz	MODEL CODE: 004.50.00010	PAGE: 4	REVISION: 0



ITEM NO.	PART NUMBER	DESCRIPTION	QTY.
3	002.00.00229	TEFLON $\Phi$ 23X10	2
4	003.00.00424	INOX SCREW 4,2 X 13	12

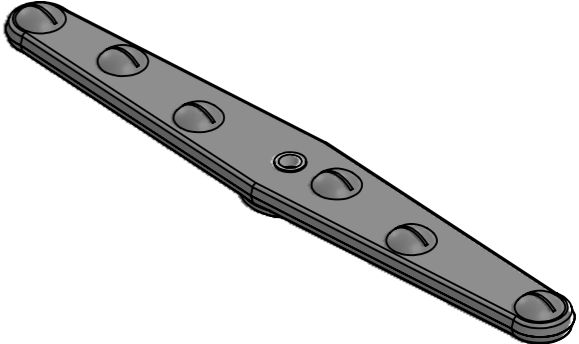
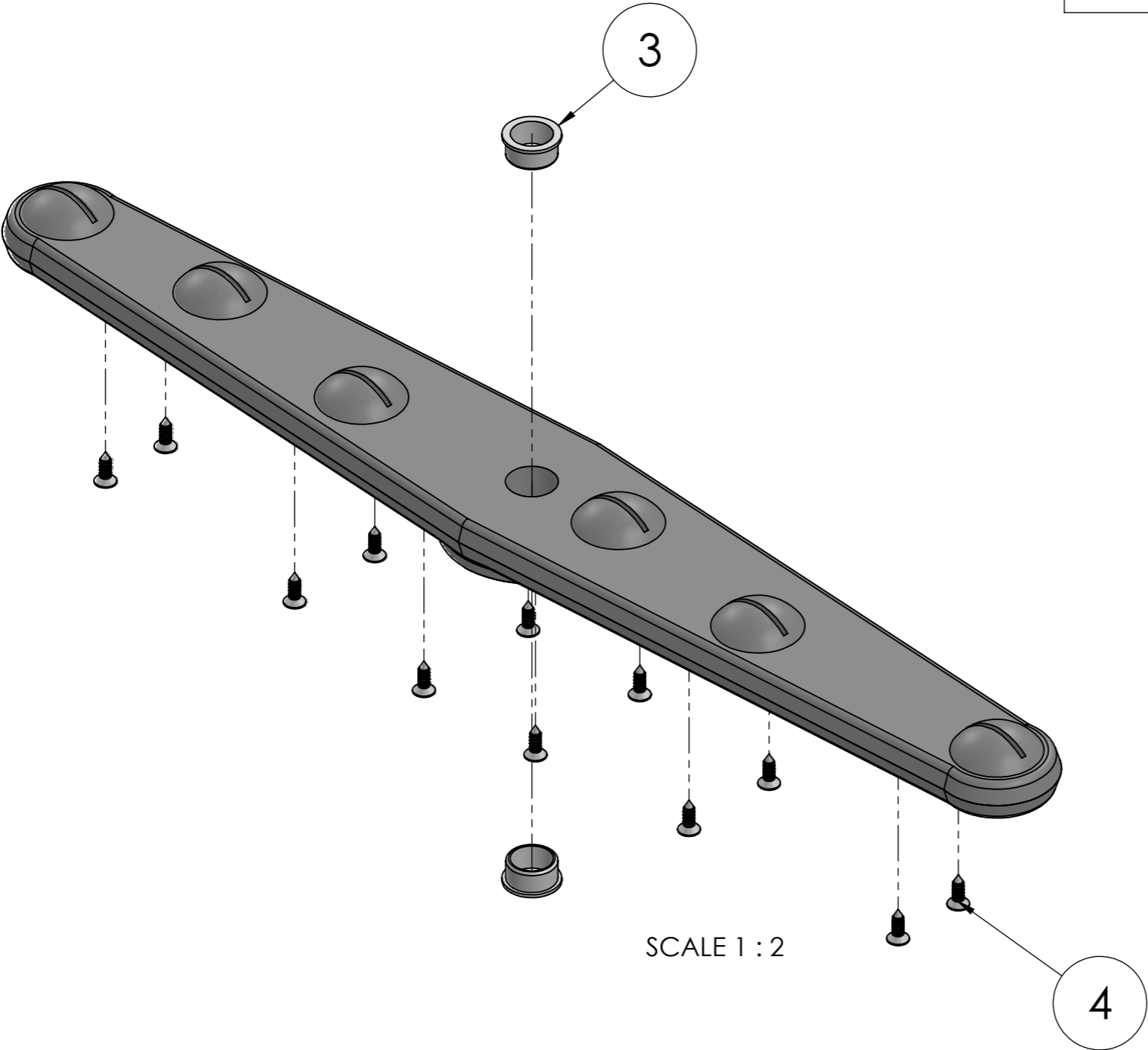

SERIES DESCRIPTION: UNDERCOUNTER		MODEL DESCRIPTION: V50		ITEM CODE: 002.50.00006	ITEM DESCRIPTION: LOWER WASHING ARM V50	
		MODEL VERSION: VERGINA50 400V~3N 50/60Hz		MODEL CODE:004.50.00010	PAGE: 1	REVISION: 0

ITEM NO.	PART NUMBER	DESCRIPTION	QTY.
1	002.50.00025	PLASTIC BASE FOR RINSING ARMS	1
2	002.50.00005 (B)	RINSING ARM SINGLE - B	1
3	002.50.00005 (A)	RINSING ARM - A	1
4	002.00.00230	TEFLON $\Phi$ 18X6	2
5	002.11.00008	SPRAYER FOR RINSING ARM	6
6	002.35.00047	CAP FOR RINSE ARMS	2

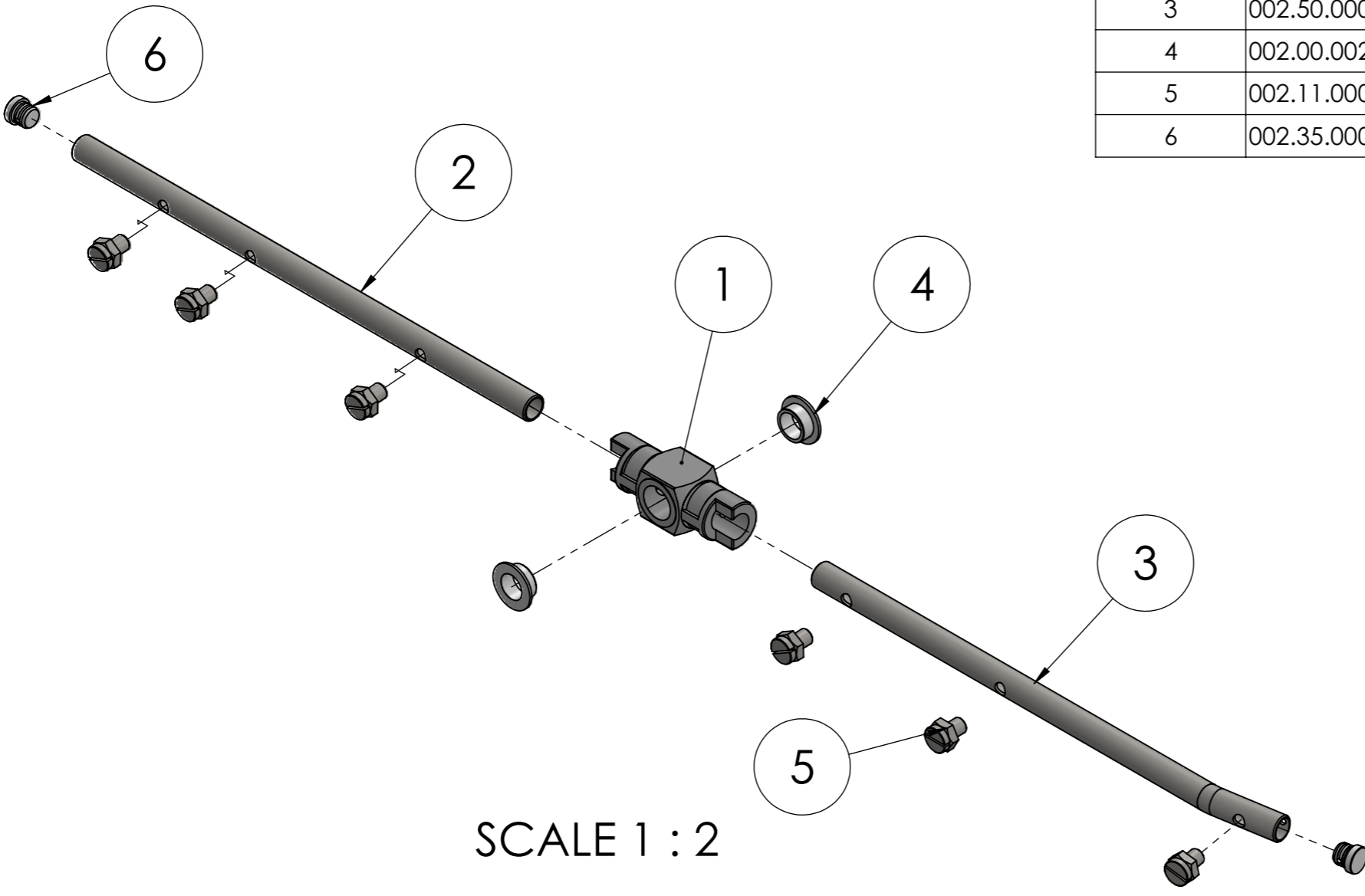

SCALE 1 : 2



SERIES DESCRIPTION: UNDERCOUNTER		MODEL DESCRIPTION: V50		ITEM CODE: 002.50.00026	ITEM DESCRIPTION: RINSING ARM UP OR DOWN V-K
		MODEL VERSION: VERGINA 50 400V~3N 50/60HZ		MODEL CODE: 004.50.00010	PAGE: 1
					REVISION: 0

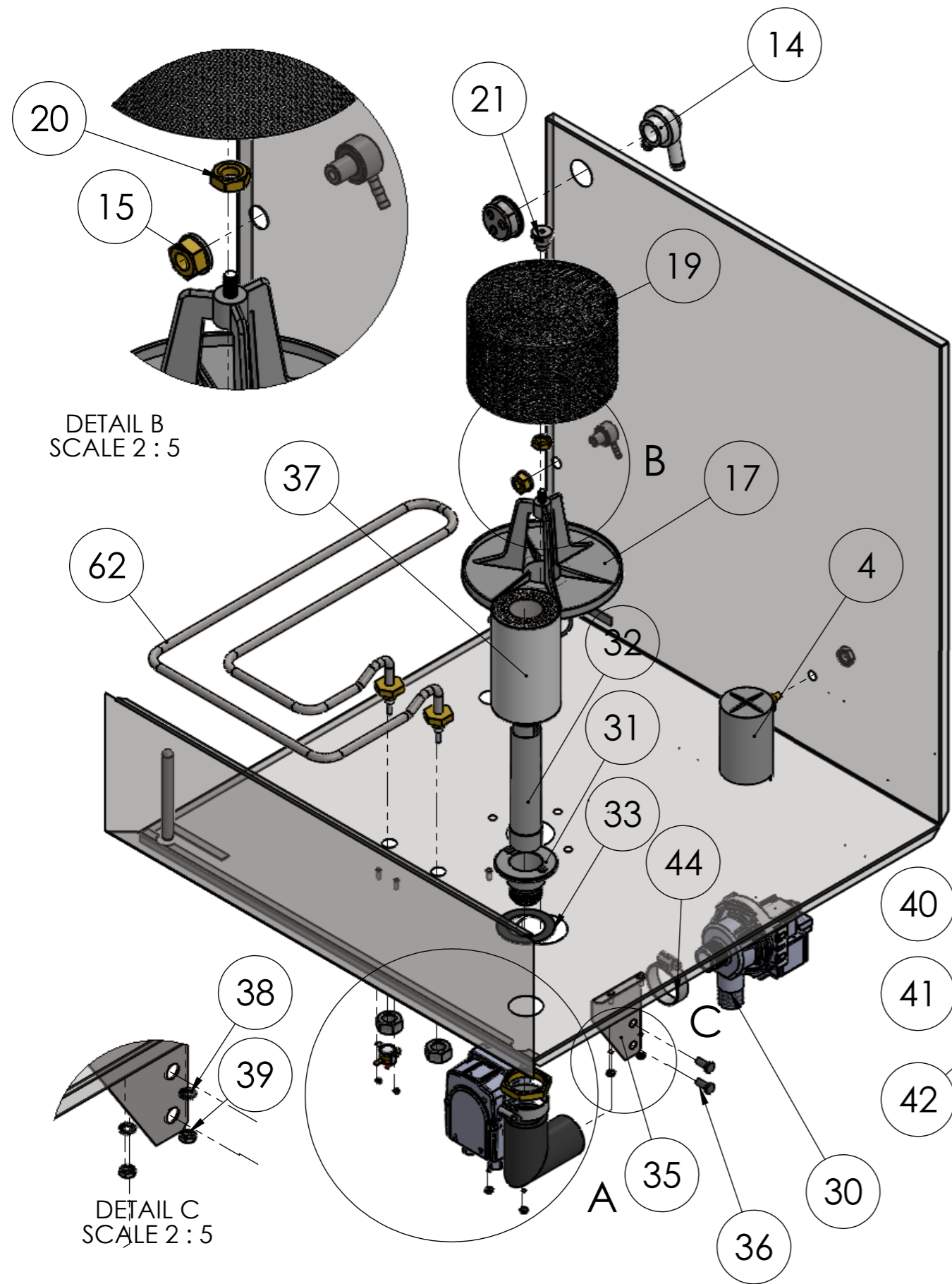

DETAIL B  
SCALE 2 : 5

DETAIL A  
SCALE 2 : 5

DETAIL C  
SCALE 2 : 5

ITEM NO.	PART NUMBER	DESCRIPTION	VERGINA/QTY.
4	003.00.00014	PRESSOSTAT CHAMBER	1
14	003.00.00269	NON RETURN VALVE (DVGW)	1
15	002.00.00233	DETERGENT TANK INJECTOR	1
17	002.00.00081	PLASTIC BASE FOR TANK FILTER V-K	1
19	002.70.00000	FILTER IN THE TANK FOR THE PUMP V-K	1
20	001.00.00093	M10 NUT INOX	1
21	001.00.00017	FILTER RETAINING NUT	1
30	003.00.00184	TANK DRAINING PUMP 230V / 65W	1
31	002.00.00257	DRAIN AND OVERFLOW VALVE PLASTIC BASE	1
32	002.70.00013	DRAIN AND OVERFLOW VALVE PLASTIC PART NEW V-K	1
33	002.00.00238	RUBBER GASKET 35X55X1	1
34	002.00.00133	BRONZE NUT M36	1
35	001.50.00065	INOX BASE FOR DRAINING PUMP V500	1
36	003.00.00485	M6 GALVANISED BOLT	2
37	001.50.00040	DRAIN PUMP FILTER V500	1
38	002.00.00140	LOCK WASHER INOX Φ4	4
39	003.00.00046	NUT M4 (GALV)	4
40	003.00.00074	NUT 14 (GALV.)	2
41	003.00.00168	TANK THERMOFUSE 90oC	1
42	002.00.00090	GALV. NUT M3	2
43	002.50.00014	DRAINING PUMP INLET PIPE V500	1
44	002.00.00048	CLAMP 25-40	2
46	003.00.00429	PERISTALTIC DETERGENT PUMP G300 / 230V	1
62	003.50.00008	HEATER ELEMENT TANK 2,8 kW / 230V	1

ITEM CODE:	ITEM DESCRIPTION: MECHANICAL EQUIPMENT
SERIES DESCRIPTION: UNDERCOUNTER	MODEL DESCRIPTION: V50
MODEL VERSION: VERGINA50 400V~ 3N 50/60Hz	MODEL CODE:004.50.00010
	PAGE: 1
	REVISION: 0

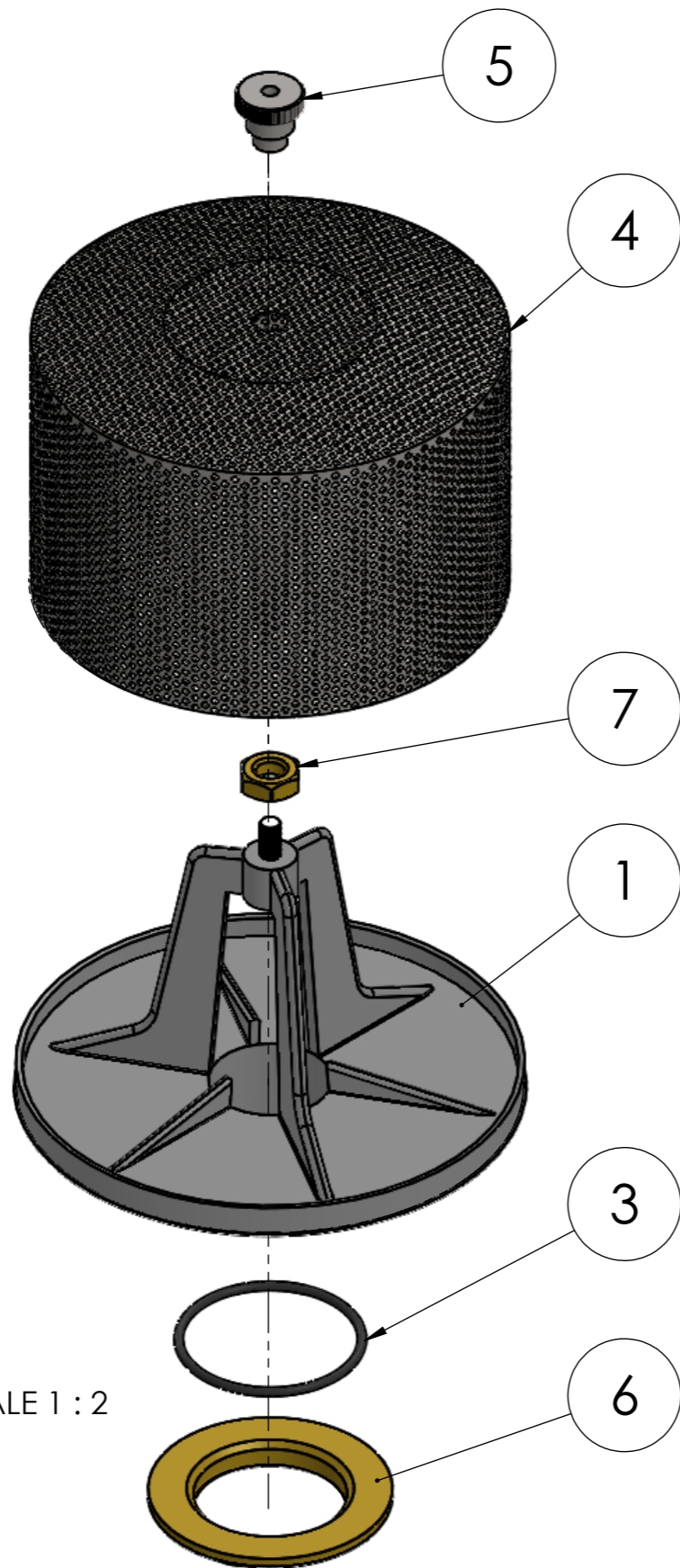

SCALE 1 : 2

ITEM NO.	PART NUMBER	DESCRIPTION	QTY.
1	002.00.00081	PLASTIC BASE FOR TANK FILTER V-K	1
3	002.00.00093	ORING 52X2,5	1
4	001.70.00000	FILTER IN THE TANK FOR THE PUMP V-K	1
5	001.00.00017	FILTER RETAINING NUT	1
6	002.00.00037	NUT 1 1/2"	1
7	001.00.00093	M10 NUT INOX	1



SCALE 1 : 2

ITEM CODE:

ITEM DESCRIPTION: TANK FILTER V-K COMPLETE

SERIES DESCRIPTION: UNDERCOUNTER

MODEL DESCRIPTION: V50

MODEL VERSION: VERGINA50  
400V~3N 50/60HZ

MODEL CODE:004.50.00010

PAGE: 1

REVISION: 0

ITEM NO.	PART NUMBER	DESCRIPTION	VERGINA 3PH/QTY.
8	003.00.00516	WASHER STEEL Ø6X18	5
9	001.00.00204	GALVANIZED LOCK WASHER 6,4x11x0,7	5
10	003.00.00041	NUT M6 GALVANISED	5
45	003.00.00268	HYDRAULIC RINSE AID PUMP	1
47	002.50.00032-1	WASH PUMP HOSE (OUTLET)	1
48	002.00.00050	CLAMP 40-60	4
49	002.00.00127-1	WASH PUMP HOSE (INPUT)	1
50	002.00.00090	GALV. BOLT M4X10	2
59	003.00.00031	WATER INPUT VALVE	1
60	003.00.00350	PUMP 0,75Hp 50Hz 230V IP44	1
61	006.50.00004	BOILER COMPLETE WITH HEATER ELEM. V500	1

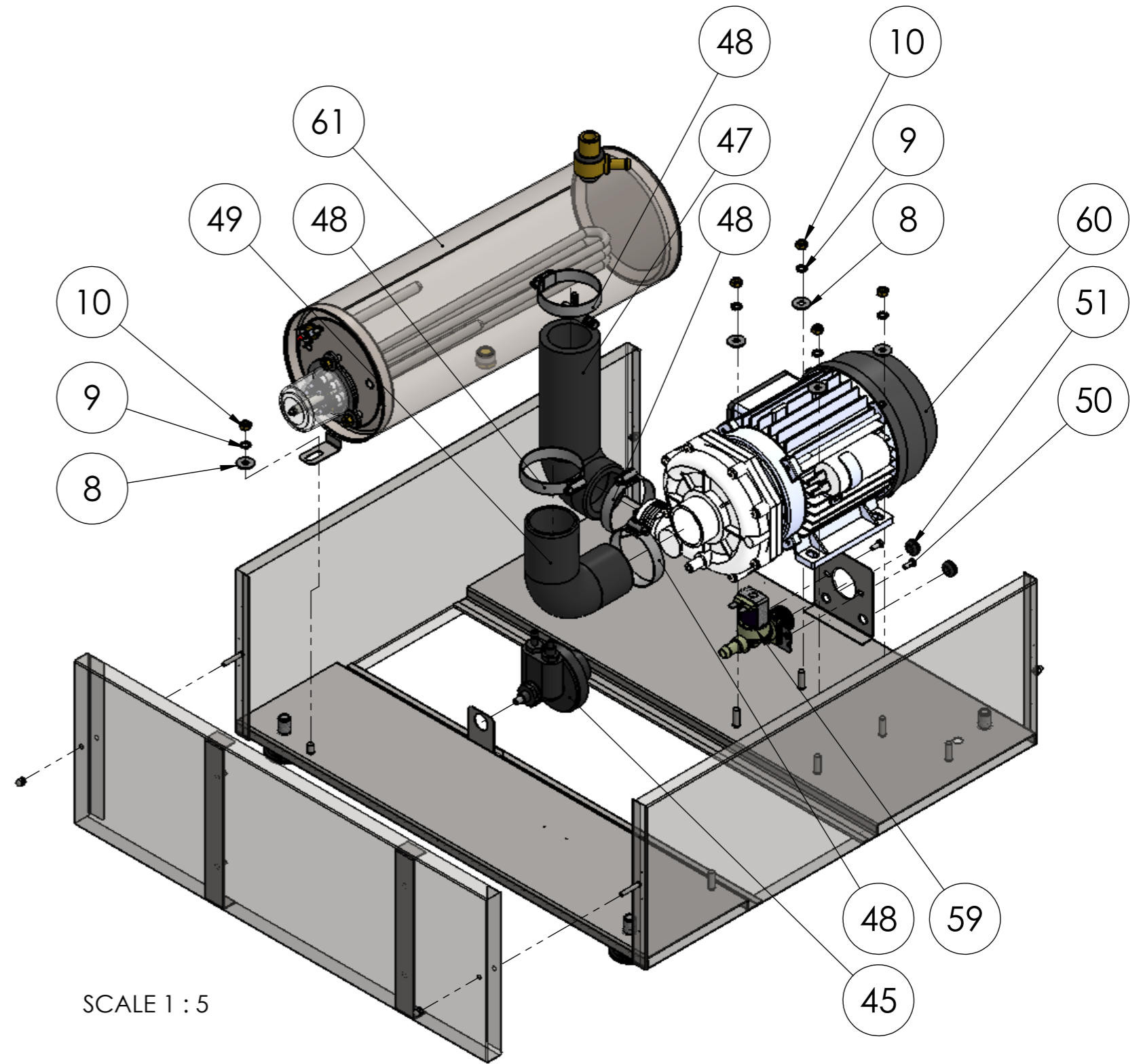

SCALE 1 : 5

SERIES DESCRIPTION: UNDERCOUNTER		MODEL DESCRIPTION: V50		ITEM CODE:	ITEM DESCRIPTION: MECHANICAL EQUIPMENT
		MODEL VERSION:VERGINA50 400V~3N 50/60Hz		MODEL CODE: 004.50.00010	PAGE: 2
					REVISION: 0

ITEM NO.	PART NUMBER	DESCRIPTION	VERGINA 3PH/QTY.
1	001.50.00017	BOILER V500 Ø140X400	1
2	002.50.00001	OUTLET BASE BOILER V500	1
3	002.00.00076	BOILER DRAIN THREADED CAP	1
4	003.00.00260	BOILER ELEMENT FITTING BASE	1
5	003.00.00516	WASHER STEEL Ø6X18	3
6	003.00.00041	NUT M6 GALVANISED	3
7	003.00.00180	BOILER THERMOFUSE 105°C	1
8	002.00.00090	GALV. NUT M3	2
9	001.00.00204	GALVANIZED LOCK WASHER 6,4x11x0,7	3
10	003.00.00004	HEATER ELEMENT COVER	1
11	003.00.00411	HEATER ELEMENT BOILER 400V VE & KN	1

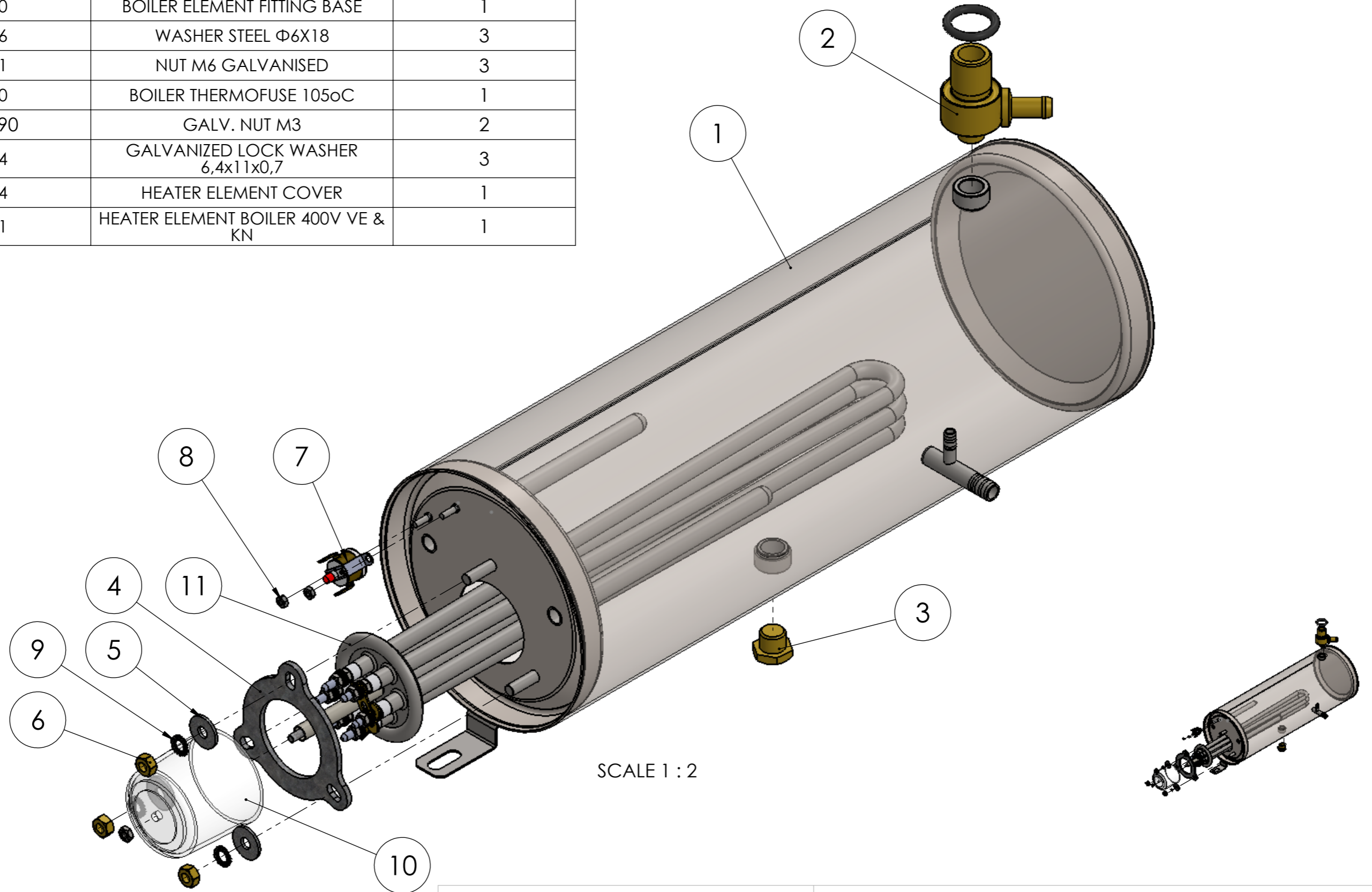

ITEM CODE: 006.50.00004

ITEM DESCRIPTION: BOILER COMPLETE WITH  
HEATER ELEMENT V50 400V

SERIES DESCRIPTION: UNDERCOUNTER

MODEL DESCRIPTION: V50

MODEL VERSION: VERGINA50 400V ~3N  
50/60Hz

MODEL CODE:004.50.00010

PAGE: 1

REVISION: 0